

LEMPCO®

Manufacturing With The Highest
Precision Level Available

NEW LOOK, SAME TRADITION

INTRODUCTION

LEMPCO®

LEMPCO is proud to introduce our new all-inclusive premium product catalog! This new catalog incorporates numerous upgrades to the brand, specifically product improvements, superior appearance and a new logo. With a bold and modern statement created for the brand, this catalog has been color-coded to easily locate product information.

As an internationally recognized manufacturer of die sets and guidance systems, **LEMPCO** has been servicing major industries, including canning, electronics, automotive, appliance, plastics, computer and specialty items, since 1918. Long recognized as the standard for excellence in the industry, and known by our extremely high quality and reliability, **LEMPCO** products are in demand worldwide.

PRODUCT IMPROVEMENTS

Always working hard to bring new solutions to customers, **LEMPCO** Ball Cages have been completely redesigned with several product improvements. The newly improved orbital staking enhances the reliability of ball bearing retention and prevents the loss of ball bearings during use. The Ball Cages are now black anodized to provide a protective hard coating which improves function and helps eliminate material flaking during operation. We have also added additional ball bearings on each retainer which increases bearing surface. These improved Ball Cages allow metal stampers to achieve high-speed press production with less frequent replacements, thus avoiding costly downtime. Overall, the orbital staking lowers the Ball Cage stress levels during production and improves the operational life cycle performance.

SAME INDUSTRY TRADITIONS

Although we have a new look, **LEMPCO** uses the same traditions we have always had. We pledge that all **LEMPCO** products, innovative or conventional, will be manufactured to the same high level of accuracy you have always known. To ensure you are receiving the high quality you expect from us, we stamp the **LEMPCO** name on every part we manufacture, which means satisfaction in terms of quality, dependability and service. The pride we have in our ability to perform and provide you with profitable production with our die sets and components is the foundation of our business.

CUSTOMER SATISFACTION

Backed by years of experience and a renewed commitment to our customers, **LEMPCO** understands customer needs and ensures cost-effective products and complete satisfaction. We recognize the value of maintaining relationships and can help meet the needs of quick deliveries, competitive prices and high quality parts. Our extensive **LEMPCO** distribution network, sales personnel and technical engineers will work closely with you to make sure your specifications are met.

CAD FILES

LEMPCO component product line is NOW available on-line in 2D/3D CAD formats. To download the templates, visit our website at www.lempco.com or contact us at 800-652-6462.



LEMPCO guidance systems are considered the quality standard in can making dies and tooling systems worldwide. Find out how our new enhancements of our Retainer/Rotainer® products can improve your performance.

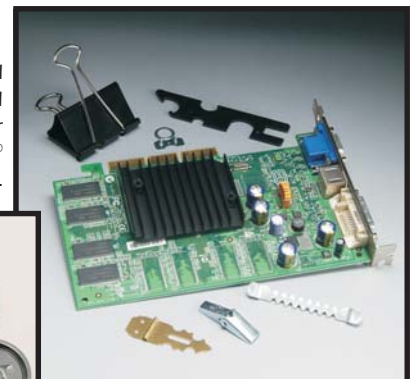

LEMPCO[®] PRODUCTS

Pins & Bushings — Inch ----- 2
Engineering & Technical Data ----- 15

Pins & Bushings — Metric ----- 20
Engineering Data ----- 28

Die Springs ----- 29

Die Sets ----- 40

Specialty Items ----- 46

THE LEMPCO VALUE PROPOSITION

- ◆ **LEMPCO** is a recognized leader in providing quality ball bearing components:
 1. Rotainer[®] designed ball cage that minimizes tracking.
 2. Precision Rotainer[®] and retainer that provides accuracy and repeatability in high speed applications.
 3. Quality pins and bushings are made from 52100 tool steel and are precision ground.
- ◆ **LEMPCO** offers high quality die sets with either **LEMPCO** ball bearing or Lamina plain bearing components. Pins and bushings are manufactured using high quality steel and are precision ground.
- ◆ **LEMPCO** has a strong distribution network located around the world to service our valued customers.
- ◆ **LEMPCO** manufacturing capabilities allow larger size die sets to be offered (240 in. by 120 in.) and complex machining to be available with exceptional deliveries.



QUALITY ■ DEPENDABILITY ■ SERVICE

SINCE 1918

THE GLOBAL STANDARD WITH DISTRIBUTORS WORLDWIDE

ROTAINERS®

FOR BALL BEARING APPLICATIONS

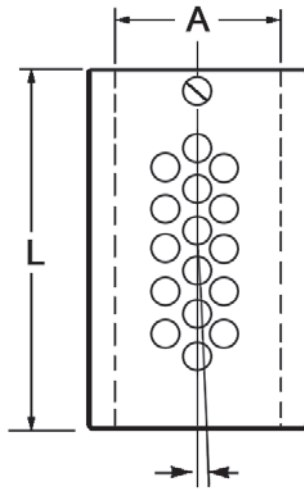

Radial bearing placement reduces wear and tracking.

Designed to rotate on the post, as well as maintain its vertical motion, **LEMPCO** ROTAINERS® were developed to greatly reduce the amount of tracking. The disengagement of the guide post from the bushing by 1/4" at the top of the stroke will allow the ROTAINER® to rotate 360° on the guide post. The ROTAINER®, while still designed to track, (assuring a measurable amount of preload) will enable stampers to achieve high press production by reducing expensive replacement costs.

Rotainer® Slide Replacement with Screw Assembly		Number of Inserts
Nom.	Assembly Part No.	
3/4	06CLIP	1
1	08CLIP	1
1 1/4	10CLIP	1
1 1/2	12CLIP	1
1 3/4	14CLIP	1
2	16CLIP	2
2 1/2	20CLIP	2
3	24CLIP	2

NOTES:

- ◆ Diameters and lengths not listed are available by special order.
- ◆ The LAST length for each diameter shown in the table at right should be used for general die set applications. Other lengths are for limited space and special applications.
- ◆ Under a preloaded condition, the ROTAINER® will only move vertically.

Nom. Post Diameter A	Length (in) L	Catalog Number
3/4	1 1/2	361-0606
	1 3/4	361-0607
	2	361-0608
	2 1/4	361-0609
	2 1/2	361-0610
1	1 1/2	361-0806
	1 3/4	361-0807
	2	361-0808
	2 1/4	361-0809
	2 1/2	361-0810
1 1/4	2	361-1008
	2 1/4	361-1009
	2 1/2	361-1010
	2 3/4	361-1011
	3	361-1012
	3 1/4	361-1013
1 1/2	2 1/2	361-1210
	2 3/4	361-1211
	3	361-1212
	3 1/4	361-1213
	3 1/2	361-1214
	3 3/4	361-1215
1 3/4	2 3/4	361-1411
	3	361-1412
	3 1/4	361-1413
	3 1/2	361-1414
	3 3/4	361-1415
	4	361-1416
2	4 1/4	361-1417
	3 1/4	361-1613
	3 1/2	361-1614
	3 3/4	361-1615
	4	361-1616
	4 1/4	361-1617
2 1/2	4 1/2	361-1618
	3 1/4	361-2013
	4	361-2016
	4 1/2	361-2018
	5	361-2020
	6	361-2024
3	6 1/2	361-2026
	7	361-2028
	5	361-2420
	6	361-2424
	7	361-2428

PRECISION BALL BEARING RETAINERS

FOR BALL BEARING APPLICATIONS

Nom. Post Diameter A	Length (in) L	Catalog Number
3/4	1 1/2	931-0606
	1 3/4	931-0607
	2	931-0608
	2 1/4	931-0609
	2 1/2	931-0610
1	1 1/2	931-0806
	1 3/4	931-0807
	2	931-0808
	2 1/4	931-0809
	2 1/2	931-0810
1 1/4	2	931-1008
	2 1/4	931-1009
	2 1/2	931-1010
	2 3/4	931-1011
	3	931-1012
	3 1/4	931-1013
1 1/2	2 1/2	931-1210
	2 3/4	931-1211
	3	931-1212
	3 1/4	931-1213
	3 1/2	931-1214
	3 3/4	931-1215
1 3/4	2 3/4	931-1411
	3	931-1412
	3 1/4	931-1413
	3 1/2	931-1414
	3 3/4	931-1415
	4	931-1416
	4 1/4	931-1417
2	3 1/4	931-1613
	3 1/2	931-1614
	3 3/4	931-1615
	4	931-1616
	4 1/4	931-1617
	4 1/2	931-1618
2 1/2	3 1/4	931-2013
	4	931-2016
	4 1/2	931-2018
	5	931-2020
	6	931-2024
	6 1/2	931-2026
	7	931-2028
3	5	931-2420
	6	931-2424
	7	931-2428

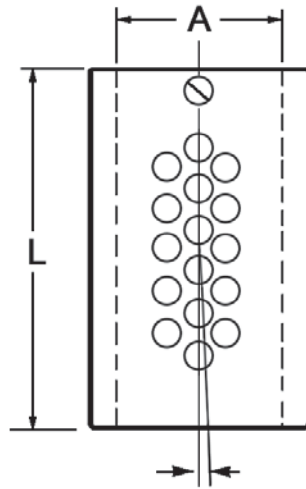

Radial bearing placement reduces wear and tracking.



LEMPCO Precision Ball Bearing Retainers possess resistance to normal wear and to lateral motion, are smooth in high speed operation and offer precise die register. They are keyed to the guide post slot with a set screw.

NOTE:

- ◆ The LAST length for each diameter shown in the above table should be used for general die set applications. Other lengths are for limited space and special applications.

DEMOUNTABLE STEEL GUIDE POST BUSHINGS FOR BALL BEARING APPLICATIONS



LEMPCO Demountable Guide Post Bushings are manufactured from 52100 tool steel and precision machined. Diameters and lengths not listed are available by special order. Required clamps and screws are included.

Nom. Post Diameter	B	C	E	F	Radius		L	Catalog Numbers	
					M	N			
1	1.7154	2	1	7/8	1.219	1.594	2	962-0808	
				1 1/8			2 1/4	962-0809	
				1 3/8			2 1/2	962-0810	
				1 5/8			3 clamps & screws provided	2 3/4	962-0811
				1 7/8				3	962-0812
				2 1/8				3 1/4	962-0813
				2 3/8				3 1/2	962-0814
				2 5/8				3 3/4	962-0815
				1 1/4			2.1054	2 3/8	1
1 5/8	2 3/4	962-1011							
1 7/8	3	962-1012							
2 1/8	3 1/4	962-1013							
2 3/8	3 1/2	962-1014							
2 5/8	3 clamps & screws provided	3 3/4	962-1015						
2 7/8		4	962-1016						
3 1/8		4 1/4	962-1017						
3 3/8		4 1/2	962-1018						
3 7/8		5	962-1020						
4 3/8		5 1/2	962-1022						
4 7/8		6	962-1024						
1 1/2	2.4354	2 11/16	1 1/4	1 5/8	1.598	2.020	3	962-1212	
				1 7/8			3 1/4	962-1213	
				2 1/8			3 1/2	962-1214	
				2 3/8			3 3/4	962-1215	
				2 5/8			4	962-1216	
				2 7/8			3 clamps & screws provided	4 1/4	962-1217
				3 1/8				4 1/2	962-1218
				3 3/8				4 3/4	962-1219
				3 5/8				5	962-1220
				3 7/8				5 1/4	962-1221
				4 1/8				5 1/2	962-1222
				4 5/8				6	962-1224
				1 3/4			2.7454	3	1 1/4
2 1/8	3 1/2	962-1414							
2 3/8	3 3/4	962-1415							
2 5/8	4	962-1416							

DEMOUNTABLE STEEL GUIDE POST BUSHINGS

FOR BALL BEARING APPLICATIONS

Nom. Post Diameter	B	C	E	F	Radius		L	Catalog Numbers	
					M	N			
1 3/4	2.7454	3	1 1/4	2 7/8	1.754	2.176	4 1/4	962-1417	
				3 1/8			4 1/2	962-1418	
				3 3/8			4 3/4	962-1419	
				3 5/8			5	962-1420	
				3 7/8			4 clamps & screws provided	5 1/4	962-1421
				4 1/8				5 1/2	962-1422
				4 5/8				6	962-1424
				5 1/8				6 1/2	962-1426
				5 5/8				7	962-1428
				6 1/8				7 1/2	962-1430
2	3.1604	3 9/16	1 1/4	1 5/8	2.035	2.457	3	962-1612	
				2 1/8			3 1/2	962-1614	
				2 3/8			3 3/4	962-1615	
				2 5/8			4	962-1616	
				2 7/8			4 1/4	962-1617	
				3 1/8			4 clamps & screws provided	4 1/2	962-1618
				3 3/8				4 3/4	962-1619
				3 5/8				5	962-1620
				3 7/8				5 1/4	962-1621
				4 1/8				5 1/2	962-1622
				4 5/8				6	962-1624
				5 1/8				6 1/2	962-1626
				5 5/8			7	962-1628	
6 1/8	7 1/2	962-1630							
2 1/2	3.6804	4 1/16	1 1/4	3 5/8	2.259	2.681	5	962-2020	
				4 1/8			5 1/2	962-2022	
				4 5/8			6	962-2024	
				5 1/8			6 1/2	962-2026	
				5 5/8			7	962-2028	
				6 1/8			7 1/2	962-2030	
3	4.1804	4 9/16	1 1/4	3 5/8	2.531	2.953	5	962-2420	
				4 1/8			5 1/2	962-2422	
				4 5/8			6	962-2424	
				5 1/8			6 1/2	962-2426	
				5 5/8			7	962-2428	
				6 1/8			7 1/2	962-2430	

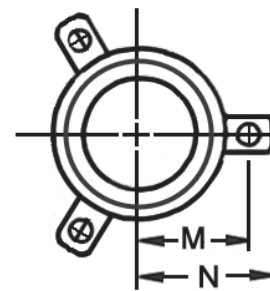
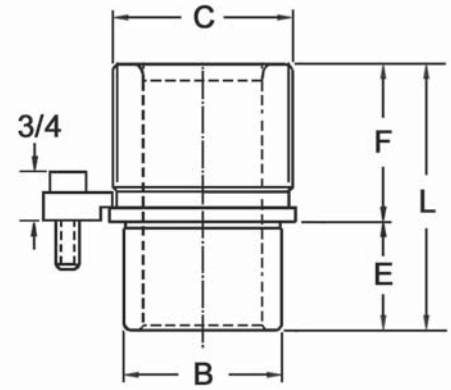

NOTE:

- ◆ The "C" dimension measurement is from the outside edge of the flange to the opposite outside edge.

SHOULDER GUIDE POST BUSHINGS

FOR BALL BEARING APPLICATIONS



Nom. Post Diameter	B	C	E	F	Radius		L	Catalog Numbers
					M	N		
1	1.725	2	1	7/8	1.219	1.594	2	963-0808
				1 1/8			2 1/4	963-0809
				1 3/8			2 1/2	963-0810
				1 5/8			2 3/4	963-0811
				1 7/8			3	963-0812
				2 1/8			3 1/4	963-0813
				2 3/8			3 1/2	963-0814
				2 5/8			3 3/4	963-0815
1 1/4	2.115	2 3/8	1	1 3/8	1.442	1.864	2 1/2	963-1010
				1 5/8			2 3/4	963-1011
				1 7/8			3	963-1012
				2 1/8			3 1/4	963-1013
				2 3/8			3 1/2	963-1014
				2 5/8			3 3/4	963-1015
				2 7/8			4	963-1016
				3 1/8			4 1/4	963-1017
				3 3/8			4 1/2	963-1018
				3 7/8			5	963-1020
				4 3/8			5 1/2	963-1022
4 7/8	6	963-1024						
1 1/2	2.445	2 11/16	1 1/4	1 5/8	1.598	2.020	3	963-1212
				1 7/8			3 1/4	963-1213
				2 1/8			3 1/2	963-1214
				2 3/8			3 3/4	963-1215
				2 5/8			4	963-1216
				2 7/8			4 1/4	963-1217
				3 1/8			4 1/2	963-1218
				3 3/8			4 3/4	963-1219
				3 5/8			5	963-1220
				3 7/8			5 1/4	963-1221
				4 1/8			5 1/2	963-1222
4 5/8	6	963-1224						

Shoulder Guide Post Bushings are manufactured from 52100 tool steel and precision ground. They are similar to **LEMPCO** Steel Demountable Bushings but are a minimum of .008" larger on the mounting diameter, corresponding to the additional material on the Shoulder Guide Post. They may be installed either by tap or press fitting. These bushings are interchangeable. See pages 13–15 for mounting instructions.

Required clamps and screws are included.

SHOULDER GUIDE POST BUSHINGS

FOR BALL BEARING APPLICATIONS

Nom. Post Diameter	B	C	E	F	Radius		L	Catalog Numbers
					M	N		
1 3/4	2.755	3	1 1/4	1 5/8	1.754	2.176	3	963-1412
				2 1/8			3 1/2	963-1414
				2 3/8			3 3/4	963-1415
				2 5/8			4	963-1416
				2 7/8			4 1/4	963-1417
				3 1/8			4 1/2	963-1418
				3 3/8			4 3/4	963-1419
				3 5/8			5	963-1420
				3 7/8			5 1/4	963-1421
				4 1/8			5 1/2	963-1422
				4 5/8			6	963-1424
				5 1/8			6 1/2	963-1426
				5 5/8			7	963-1428
6 1/8	7 1/2	963-1430						
2	3.170	3 9/16	1 1/4	1 5/8	2.035	2.457	3	963-1612
				2 1/8			3 1/2	963-1614
				2 3/8			3 3/4	963-1615
				2 5/8			4	963-1616
				2 7/8			4 1/4	963-1617
				3 1/8			4 1/2	963-1618
				3 3/8			4 3/4	963-1619
				3 5/8			5	963-1620
				3 7/8			5 1/4	963-1621
				4 1/8			5 1/2	963-1622
				4 5/8			6	963-1624
				5 1/8			6 1/2	963-1626
				5 5/8			7	963-1628
6 1/8	7 1/2	963-1630						
2 1/2	3.690	4 1/16	1 1/4	3 5/8	2.259	2.681	5	963-2020
				4 1/8			5 1/2	963-2022
				4 5/8			6	963-2024
				5 1/8			6 1/2	963-2026
				5 5/8			7	963-2028
6 1/8	7 1/2	963-2030						

NOTE:

- ◆ The 963 Series product line is not stocked, but is available as a special order.

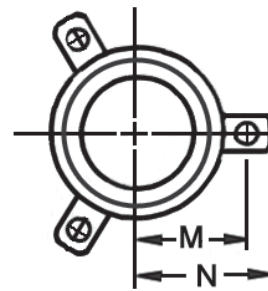
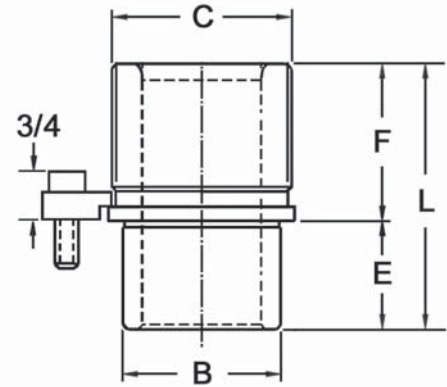

PRESS FIT STEEL SLEEVE BUSHINGS

FOR BALL BEARING APPLICATIONS

LEMPCO Press Fit Steel Sleeve Bushings are manufactured from 52100 tool steel and precision machined. The I.D. is ground and honed to an 8-12 RMS finish to minimize resistance to free action of the retainer/Rotainer® bearings. See pages 13–15 for mounting instructions.

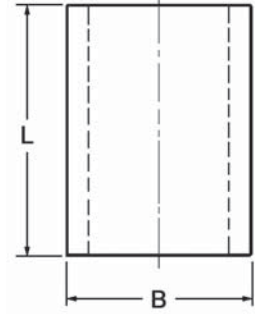

Nom. Post Diameter	B	L	Catalog Numbers
3/4	1.387	1 3/4	961-0607
		2	961-0608
		2 1/4	961-0609
		2 1/2	961-0610
		2 3/4	961-0611
		3	961-0612
		3 1/4	961-0613
		3 1/2	961-0614
		3 3/4	961-0615
		4	961-0616
		4 1/2	961-0618
		5	961-0620
		6	961-0624
1	1.717	2	961-0808
		2 1/4	961-0809
		2 1/2	961-0810
		2 3/4	961-0811
		3	961-0812
		3 1/4	961-0813
		3 1/2	961-0814
		3 3/4	961-0815
		4	961-0816
		4 1/4	961-0817
		4 1/2	961-0818
		4 3/4	961-0819
		5	961-0820
5 1/2	961-0822		
6	961-0824		
6 1/2	961-0826		
7	961-0828		
1 1/4	2.107	2 1/2	961-1010
		2 3/4	961-1011
		3	961-1012
		3 1/4	961-1013
		3 1/2	961-1014
		3 3/4	961-1015
		4	961-1016
		4 1/4	961-1017
		4 1/2	961-1018
		5	961-1020
		5 1/2	961-1022
		6	961-1024
		6 1/2	961-1026
7	961-1028		
8	961-1032		
9	961-1036		

Nom. Post Diameter	B	L	Catalog Numbers
1 1/2	2.437	3	961-1212
		3 1/4	961-1213
		3 1/2	961-1214
		3 3/4	961-1215
		4	961-1216
		4 1/4	961-1217
		4 1/2	961-1218
		4 3/4	961-1219
		5	961-1220
		5 1/4	961-1221
		5 1/2	961-1222
		6	961-1224
6 1/2	961-1226		
7	961-1228		
7 1/2	961-1230		
8	961-1232		
8 1/2	961-1234		
9	961-1236		
10	961-1240		
11	961-1244		
12	961-1248		
1 3/4	2.747	3	961-1412
		3 1/2	961-1414
		3 3/4	961-1415
		4	961-1416
		4 1/4	961-1417
		4 1/2	961-1418
		4 3/4	961-1419
		5	961-1420
		5 1/4	961-1421
		5 1/2	961-1422
		6	961-1424
		6 1/2	961-1426
		7	961-1428
7 1/2	961-1430		
8	961-1432		
8 1/2	961-1434		
9	961-1436		
10	961-1440		
11	961-1444		
12	961-1448		
13	961-1452		

Nom. Post Diameter	B	L	Catalog Numbers
2	3.162	3	961-1612
		3 1/2	961-1614
		3 3/4	961-1615
		4	961-1616
		4 1/4	961-1617
		4 1/2	961-1618
		4 3/4	961-1619
		5	961-1620
		5 1/4	961-1621
		5 1/2	961-1622
		6	961-1624
		6 1/2	961-1626
		7	961-1628
		7 1/2	961-1630
8	961-1632		
8 1/2	961-1634		
9	961-1636		
10	961-1640		
11	961-1644		
12	961-1648		
13	961-1652		
14	961-1656		
2 1/2	3.682	6	961-2024
		6 1/2	961-2026
		7	961-2028
		7 1/2	961-2030
		8	961-2032
		8 1/2	961-2034
		9	961-2036
		9 1/2	961-2038
10	961-2040		
11	961-2044		
12	961-2048		
13	961-2052		
14	961-2056		
3	4.182	6	961-2424
		6 1/2	961-2426
		7	961-2428
		7 1/2	961-2430
		8	961-2432
		8 1/2	961-2434
		9	961-2436
		10	961-2440
		11	961-2444
		12	961-2448
13	961-2452		
14	961-2456		

STRAIGHT GUIDE POSTS FOR BALL BEARING APPLICATIONS

LEMPCO Straight Guide Posts for ball bearing assemblies are manufactured from 52100 tool steel and precision ground. See pages 13–15 for mounting instructions.

Post Diameter A	Length L	Catalog Numbers
3/4 (.753)	3	951-0612
	3 1/4	951-0613
	3 1/2	951-0614
	3 3/4	951-0615
	4	951-0616
	4 1/4	951-0617
	4 1/2	951-0618
	4 3/4	951-0619
	5	951-0620
	5 1/2	951-0622
6	951-0624	
1 (1.003)	3 3/4	951-0815
	4	951-0816
	4 1/4	951-0817
	4 1/2	951-0818
	4 3/4	951-0819
	5	951-0820
	5 1/4	951-0821
	5 1/2	951-0822
	5 3/4	951-0823
	6	951-0824
	6 1/2	951-0826
	7	951-0828
	7 1/2	951-0830
	8	951-0832
	8 1/2	951-0834
	9	951-0836
	10	951-0840
	11	951-0844
12	951-0848	
1 1/4 (1.253)	4 1/2	951-1018
	4 3/4	951-1019
	5	951-1020
	5 1/4	951-1021
	5 1/2	951-1022
	5 3/4	951-1023
	6	951-1024
	6 1/2	951-1026
	7	951-1028
	7 1/2	951-1030
	8	951-1032
	8 1/2	951-1034
	9	951-1036
	10	951-1040
11	951-1044	
12	951-1048	

Post Diameter A	Length L	Catalog Numbers
1 1/2 (1.503)	4 1/2	951-1218
	4 3/4	951-1219
	5	951-1220
	5 1/4	951-1221
	5 1/2	951-1222
	5 3/4	951-1223
	6	951-1224
	6 1/2	951-1226
	7	951-1228
	7 1/2	951-1230
	8	951-1232
	8 1/2	951-1234
	9	951-1236
	9 1/2	951-1238
10	951-1240	
10 1/2	951-1242	
11	951-1244	
11 1/2	951-1246	
12	951-1248	
12 1/2	951-1250	
13	951-1252	
14	951-1256	
1 3/4 (1.753)	5	951-1420
	5 1/4	951-1421
	5 1/2	951-1422
	5 3/4	951-1423
	6	951-1424
	6 1/4	951-1425
	6 1/2	951-1426
	7	951-1428
	7 1/2	951-1430
	8	951-1432
	8 1/2	951-1434
	9	951-1436
	9 1/2	951-1438
	10	951-1440
10 1/2	951-1442	
11	951-1444	
11 1/2	951-1446	
12	951-1448	
12 1/2	951-1450	
13	951-1452	
14	951-1456	
15	951-1460	
17	951-1468	

Post Diameter A	Length L	Catalog Numbers
2 (2.003)	5 1/2	951-1622
	5 3/4	951-1623
	6	951-1624
	6 1/4	951-1625
	6 1/2	951-1626
	6 3/4	951-1627
	7	951-1628
	7 1/4	951-1629
	7 1/2	951-1630
	7 3/4	951-1631
	8	951-1632
	8 1/2	951-1634
	9	951-1636
	9 1/2	951-1638
	10	951-1640
	10 1/2	951-1642
	11	951-1644
	11 1/2	951-1646
12	951-1648	
12 1/2	951-1650	
13	951-1652	
14	951-1656	
15	951-1660	
16	951-1664	
17	951-1668	
18	951-1672	
2 1/2 (2.503)	8	951-2032
	8 1/2	951-2034
	9	951-2036
	10	951-2040
	11	951-2044
	12	951-2048
	13	951-2052
	14	951-2056
17	951-2068	
20	951-2080	
3 (3.003)	8	951-2432
	8 1/2	951-2434
	9	951-2436
	10	951-2440
	11	951-2444
	12	951-2448
	13	951-2452
	14	951-2456
17	951-2468	
20	951-2480	

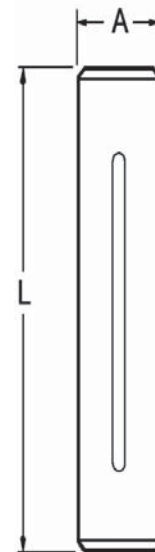

FLANGED DEMOUNTABLE GUIDE POSTS FOR BALL BEARING APPLICATIONS



LEMPCO Flanged Demountable Guide Posts for ball bearing assemblies are designed for those who prefer the convenience of a removable post to expedite die repairs. The post is tap fitted into the pin plate bore with the flange flush to the ground surface. See page 13 for bore size data.

These Demountable Guide Posts are manufactured from 52100 tool steel.

Required clamps and screws are included.

Diameter			Nominal Length					Catalog Numbers	
Post A	Flange B	C	E	F	Radius		L		
					M	N			
1 (1.003)	1 5/16	1.0009 1.0006	1 3/16	2 1/2	13/16	1 1/8	3 clamps & screws provided	3 3/4	956-0815
				2 3/4				4	956-0816
				3				4 1/4	956-0817
				3 1/4				4 1/2	956-0818
				3 1/2				4 3/4	956-0819
				3 3/4				5	956-0820
				4				5 1/4	956-0821
				4 1/4				5 1/2	956-0822
				4 1/2				5 3/4	956-0823
				4 3/4				6	956-0824
				5 1/4				6 1/2	956-0826
				5 3/4				7	956-0828
				6 1/4				7 1/2	956-0830
				6 3/4				8	956-0832
7 1/4	8 1/2	956-0834							
7 3/4	9	956-0836							
1 1/4 (1.253)	1 9/16	1.2509 1.2506	1 3/16	3 1/4	63/64	1 25/64	3 clamps & screws provided	4 1/2	956-1018
				3 1/2				4 3/4	956-1019
				3 3/4				5	956-1020
				4				5 1/4	956-1021
				4 1/4				5 1/2	956-1022
				4 1/2				5 3/4	956-1023
				4 3/4				6	956-1024
				5 1/4				6 1/2	956-1026
				5 3/4				7	956-1028
				6 1/4				7 1/2	956-1030
				6 3/4				8	956-1032
				7 1/4				8 1/2	956-1034
				7 3/4				9	956-1036
				8 3/4				10	956-1040
9 3/4	11	956-1044							
10 3/4	12	956-1048							
1 1/2 (1.503)	1 7/8	1.5009 1.5006	1 7/16	3	1 1/8	1 17/32	3 clamps & screws provided	4 1/2	956-1218
				3 1/4				4 3/4	956-1219
				3 1/2				5	956-1220
				3 3/4				5 1/4	956-1221
				4				5 1/2	956-1222
				4 1/4				5 3/4	956-1223
				4 1/2				6	956-1224
				5				6 1/2	956-1226
				5 1/2				7	956-1228
				6				7 1/2	956-1230
				6 1/2				8	956-1232
				7				8 1/2	956-1234
				7 1/2				9	956-1236
				8				9 1/2	956-1238
				8 1/2				10	956-1240
				9				10 1/2	956-1242
				9 1/2				11	956-1244
				10				11 1/2	956-1246
10 1/2	12	956-1248							
11	12 1/2	956-1250							
11 1/2	13	956-1252							
12 1/2	14	956-1256							
1 3/4 (1.753)	2 1/4	1.7509 1.7506	1 11/16	3 1/4	1 19/64	1 45/64	4 clamps & screws provided	5	956-1420
				3 1/2				5 1/4	956-1421
				3 3/4				5 1/2	956-1422
				4				5 3/4	956-1423
				4 1/4				6	956-1424
				4 1/2				6 1/4	956-1425
				4 3/4				6 1/2	956-1426

FLANGED DEMOUNTABLE GUIDE POSTS FOR BALL BEARING APPLICATIONS

Diameter			Nominal Length					Catalog Numbers	
Post A	Flange B	C	E	F	Radius		L		
					M	N			
1 3/4 (1.753)	2 1/4	1.7509 1.7506	1 11/16	5 1/4	1 19/64	1 45/64	4 clamps & screws provided	7	956-1428
				5 3/4				7 1/2	956-1430
				6 1/4				8	956-1432
				6 3/4				8 1/2	956-1434
				7 1/4				9	956-1436
				7 3/4				9 1/2	956-1438
				8 1/4				10	956-1440
				8 3/4				10 1/2	956-1442
				9 1/4				11	956-1444
				9 3/4				11 1/2	956-1446
				10 1/4				12	956-1448
				10 3/4				12 1/2	956-1450
				11 1/4				13	956-1452
				12 1/4				14	956-1456
				13 1/4				15	956-1460
15 1/4	17	956-1468							
2 (2.003)	2 1/2	2.0009 2.0006	1 15/16	3 1/2	1 27/64	1 53/64	4 clamps & screws provided	5 1/2	956-1622
				3 3/4				5 3/4	956-1623
				4				6	956-1624
				4 1/4				6 1/4	956-1625
				4 1/2				6 1/2	956-1626
				4 3/4				6 3/4	956-1627
				5				7	956-1628
				5 1/4				7 1/4	956-1629
				5 1/2				7 1/2	956-1630
				5 3/4				7 3/4	956-1631
				6				8	956-1632
				6 1/2				8 1/2	956-1634
				7				9	956-1636
				7 1/2				9 1/2	956-1638
				8				10	956-1640
				8 1/2				10 1/2	956-1642
				9				11	956-1644
				9 1/2				11 1/2	956-1646
				10				12	956-1648
				10 1/2				12 1/2	956-1650
11	13	956-1652							
12	14	956-1656							
13	15	956-1660							
14	16	956-1664							
15	17	956-1668							
16	18	956-1672							
2 1/2 (2.503)	3	2.5009 2.5006	1 15/16	6	1 43/64	2 5/64	4 clamps & screws provided	8	956-2032
				6 1/2				8 1/2	956-2034
				7				9	956-2036
				8				10	956-2040
				9				11	956-2044
				10				12	956-2048
				11				13	956-2052
				12				14	956-2056
				15				17	956-2068
18	20	956-2080							
3 (3.003)	3 1/2	3.0009 3.0006	2 7/16	5 1/2	1 59/64	2 21/64	4 clamps & screws provided	8	956-2432
				6				8 1/2	956-2434
				6 1/2				9	956-2436
				7 1/2				10	956-2440
				8 1/2				11	956-2444
				9 1/2				12	956-2448
				10 1/2				13	956-2452
				11 1/2				14	956-2456
				14 1/2				17	956-2468
17 1/2	20	956-2480							

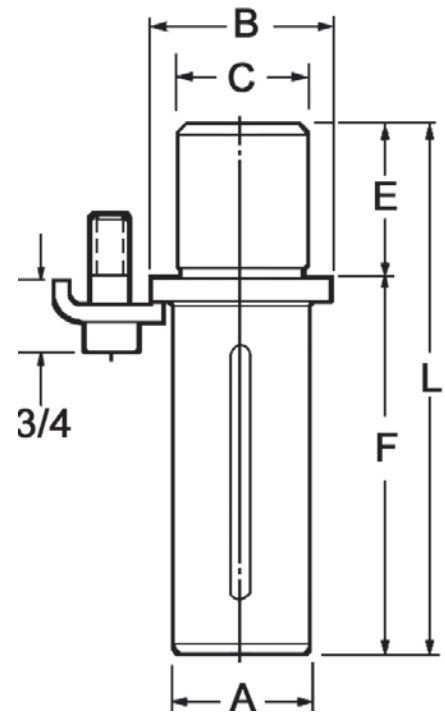

SHOULDER GUIDE POSTS FOR BALL BEARING APPLICATIONS

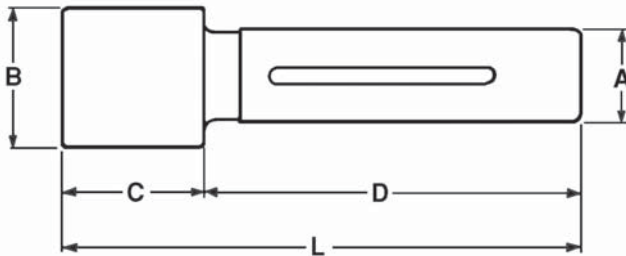

Mounting diameters of the **LEMPCO** Shoulder Guide Posts are a minimum of .008" over the sizes of Press Fit Steel Sleeve Bushings and .008" over the Demountable Steel Bushings to allow grind stock for precision fitting in new set construction and to allow reboring as necessary in replacing posts and bushings in used sets. These posts also may be used with Press Fit Sleeve Bushings and Demountable Bushings providing the through bore size accords with mounting diameters.

The Shoulder Guide Posts are manufactured from 52100 tool steel and precision ground. See pages 13–15 for mounting instructions.

Diameter A	B	Length L	C	D	Catalog Numbers
1 (1.003)	1.725	4 1/2	1 3/8	3	953-0818
		5		3 1/2	953-0820
		5 1/2		4	953-0822
		6		4 1/2	953-0824
		6 1/2		5	953-0826
		7		5 1/2	953-0828
		7 1/2		6	953-0830
		8		6 1/2	953-0832
1 1/4 (1.253)	2.115	5	1 7/8	3	953-1020
		5 1/2		3 1/2	953-1022
		6		4	953-1024
		6 1/2		4 1/2	953-1026
		7		5	953-1028
		7 1/2		5 1/2	953-1030
		8		6	953-1032
		8 1/2		6 1/2	953-1034
1 1/2 (1.503)	2.445	7	2 3/8	4 5/8	953-1228
		7 1/2		5 1/8	953-1230
		8		5 5/8	953-1232
		8 1/2		6 1/8	953-1234
		9		6 5/8	953-1236
		9 1/2		7 1/8	953-1238
		10		7 5/8	953-1240
		1 3/4 (1.753)		2.755	7 1/2
8	5 1/8		953-1432		
8 1/2	5 5/8		953-1434		
9	6 1/8		953-1436		
9 1/2	6 5/8		953-1438		
10	7 1/8		953-1440		
2 (2.003)	3.170	8	3 3/8	4 5/8	953-1632
		9		5 5/8	953-1636
		10		6 5/8	953-1640
		11		7 5/8	953-1644
		12		8 5/8	953-1648
		13		9 5/8	953-1652
2 1/2 (2.503)	3.690	9	3 7/8	5 1/8	953-2036
		10		6 1/8	953-2040
		11		7 1/8	953-2044
		12		8 1/8	953-2048
		13		9 1/8	953-2052
		14		10 1/8	953-2056

NOTE:

- ◆ The 953 Series product line is not stocked, but is available as a special order.

BALL BEARING ENGINEERING DATA

BORING PROCEDURES AND DIMENSIONS

Holes for **LEMPCO** Ball Bearing Guide Posts and Bushings should be jig bored for best results. The punch holder and dieholder should be clamped together and bored in one setup in order to maintain dead center alignment between the upper and lower bores. If it is not possible to bore in this manner, a tolerance of $\pm.0005$ " between centers (see illustration) must be held. Bores should be smooth and free from tool marks to provide proper bearing area for the guide post and bushing.

Dieholder bores must be perpendicular to the surface of the dieholder which will back up the die. The bottom surface of the dieholder must be parallel to the die backup surface. The punch holder bores also must be perpendicular to the surface which will back up the punches, and the top surface parallel to the punch backup surface.

Break the corners of the bored holes to a generous chamfer. On sets with a symmetrical profile one pin and bushing should be offset to prevent accidental reversing of the punch holder during assembly.

All of the **LEMPCO** Ball Bearing Guide Posts, Bushings Retainers and Rotainers are completely interchangeable without the need for select fitting, and if mounted in accordance with boring and assembly instructions given on this and the following page do not require any grinding, honing, lapping, or any other modifications of any kind. Please note the dimensions given in the following table. Our experience over many years proves that these are optimum dimensions. Variations must be avoided.

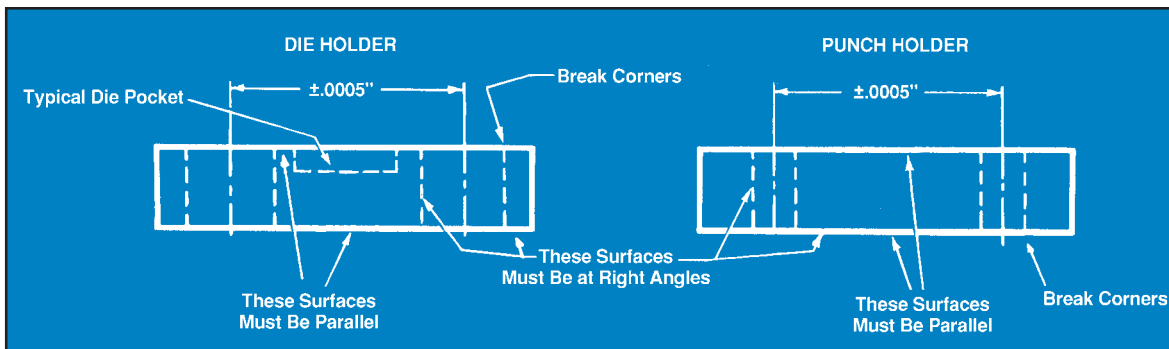

BORE CHART – BALL BEARING COMPONENTS (INCH)

Nominal Guide Post Diameter	#951-SERIES STRAIGHT GUIDE PIN (PRESS FIT)	#956-SERIES DEMOUNTABLE GUIDE PIN (TAP FIT)	#953-SERIES SHOULDER GUIDE PIN (PRESS FIT)	#961-SERIES STRAIGHT SLEEVE BUSHING (PRESS FIT)	#962-SERIES DEMOUNTABLE SHOULDER BUSHING (TAP FIT)
	BORE SIZE	BORE SIZE	BORE SIZE	BORE SIZE	BORE SIZE
3/4	0.7515 / 0.7510	N/A	N/A	1.3872 / 1.3867	N/A
1	1.0015 / 1.0010	1.0016 / 1.0009	BORE HOLE .0009" TO .0019" SMALLER THAN SHOULDER DIAMETER OF GUIDE POST	1.7172 / 1.7167	1.7159 / 1.7154
1 1/4	1.2510 / 1.2505	1.2516 / 1.2509		2.1072 / 2.1067	2.1059 / 2.1054
1 1/2	1.5010 / 1.5005	1.5016 / 1.5009		2.4372 / 2.4367	2.4359 / 2.4354
1 3/4	1.7510 / 1.7505	1.7516 / 1.7509		2.7472 / 2.7467	2.7459 / 2.7454
2	2.0006 / 2.0001	2.0016 / 2.0009		3.1622 / 3.1617	3.1608 / 3.1603
2 1/2	2.5006 / 2.5001	2.5016 / 2.5009		3.6822 / 3.6817	3.6809 / 3.6804
3	3.0006 / 3.0001	3.0016 / 3.0009	N/A	4.1822 / 4.1817	4.1809 / 4.1804

BALL BEARING ENGINEERING DATA

INSTALLATION AND ASSEMBLY INSTRUCTIONS

In order to maintain the die and punch alignment, it is essential that the guide posts and bushings be at absolute right angles with the punch and die backup surfaces.

Figure 1 represents a typical guide post and ROTAINER®. Please note that the end of the guide post with the *small radius* is press fit into the punch shoe, and that the ROTAINER® is assembled with the ROTAINER® slide assembly toward the same end of the guide post.

NOTE: LEMPCO Demountable Bushings and Flanged Demountable Guide Posts are tap fitted. Bores should be to specifications, and both bushings and guide posts should be seated flush to ground surface of support shoe and held securely by clamps and cap screws. These bushings and guide posts are removable; on installation the die will register accurately.

Check the squareness of the guide post or bushing with a precision square. Tap the sides slightly with a soft hammer until the guide post or bushing is perpendicular.

Press fit about 1/4" (6.35mm) and check with the precision square again, tapping the sides with a soft hammer as necessary, to ensure squareness. A bronze, babbitt or fiber hammer is recommended.

NOTE: With Demountable Boss Bushings, be sure to press against the hardened liner and not against the casting.

Press fit by small increments – not over 1/2" (12.70mm) each – checking with the precision square after each press. Do not allow guide post or bushing to protrude through the lower side of the plate. It is advisable to place a 1/64"

(.3968mm) shim under the guide post or bushing as a stop.

For Demountable Boss Bushings and Demountable Bushings, after the bushing is tap fit to the shoulder, the shoe may be drilled with the bushing in place. Tighten screws gradually, moving from one to another until all are tight.

After complete assembly of the bushings, check the ID top and bottom for taper. Should taper be found, hone the ID until original size is obtained.

NOTE: This should not be necessary if boring instructions were strictly adhered to.

Assemble ROTAINER® to guide post (**Figure 1**) by screwing the set screw in until flush with the special ROTAINER® slide. Vertical and the rotational movement should now be tested to insure freedom of movement. After testing is completed, stake set screw. Lubricate only with a light spindle oil.

NOTE: The only tool necessary to assemble the ROTAINER® is a screw driver.

Assemble the punch and die holder. Be sure to allow the ROTAINERS® to hang free (see **Figure 2**) supported by the special ROTAINER® slide when assembling the die set. Work the punch holder up and down a few times to assure there is no binding.

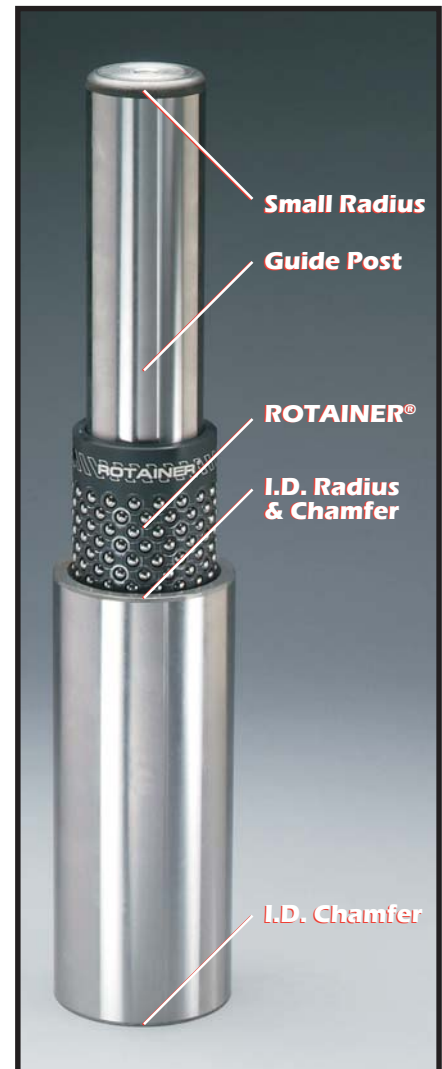

FIGURE 1

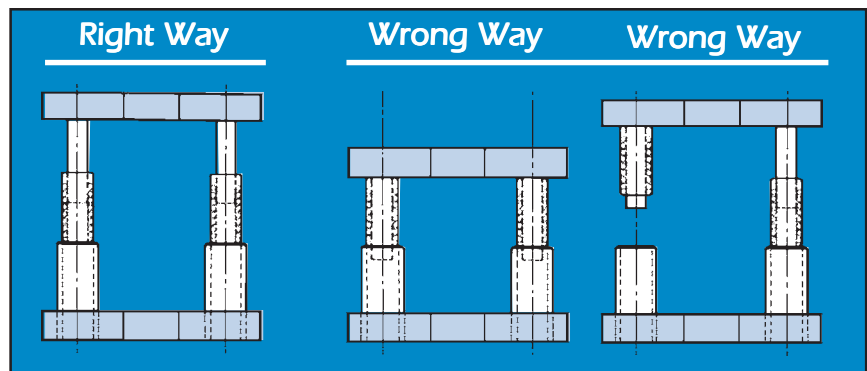

FIGURE 2

BALL BEARING ENGINEERING DATA

GENERAL DIE SET DESIGN PROCEDURES

SPECIFICATIONS:

1. Maximum Shut Height – See Figure 2, below.
2. Minimum Shut Height – See Figure 1.
3. Stroke – See Figures 2 and 3.
4. Maximum Open Height – See Figures 2 and 3.

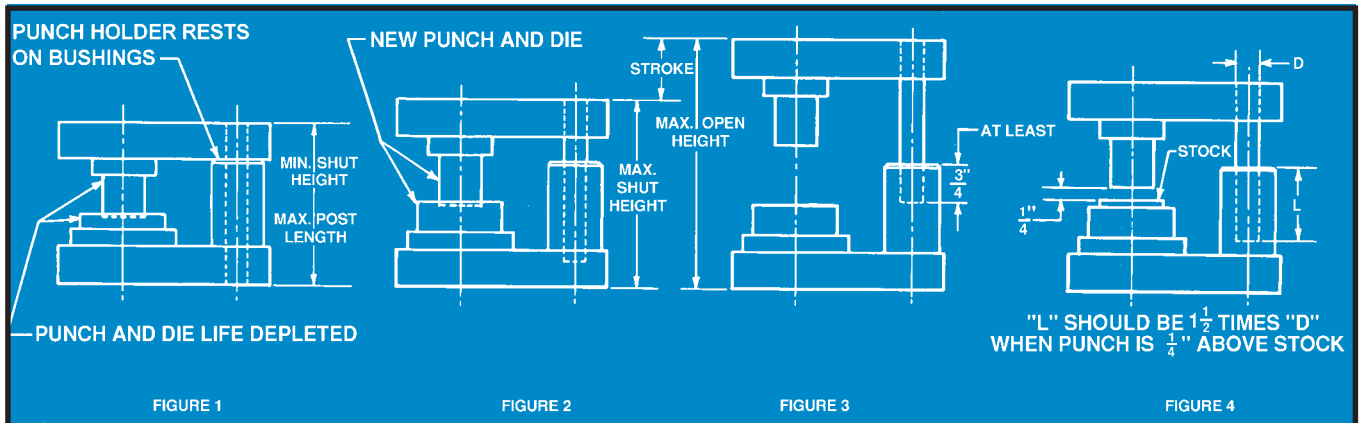

- A. Lay out die as in **Figure 1** (Minimum Shut Height). This determines maximum guide post length and maximum bushing height.
- B. Lay out die as in **Figure 2** (Maximum Shut Height).
- C. Maximum Open Height (Maximum Shut Height plus Stroke) as in **Figure 3** shows minimum guide post engagement in bushing that is required. If this is at least $\frac{3}{4}$ " then conditions are ideal. However, if this dimension is less than $\frac{3}{4}$ " then **Figure 4** should be considered. Actual work is done for only a fraction of the total stroke on most dies and if conditions shown in **Figure 4** are satisfied in conjunction with **Figure 1** and **Figure 2**, then full length of stroke and maximum open height can be disregarded.

ALSO NOTE, HOWEVER, THAT LONGER THAN NORMAL STROKES MAY BE UTILIZED BY DISENGAGING GUIDE POST AND, IF ABSOLUTELY NECESSARY, THE ROTAINER® FROM THE BUSHING ON THE UPWARD TRAVEL PROVIDED:

- 1 – THE OPERATION IS VERTICAL
- 2 – THE OPERATION IS NOT FASTER THAN 150 STROKES PER MINUTE, AND
- 3 – THE INSIDE DIAMETER OF THE BUSHING IS BELL MOUTHED MINIMUM $\frac{1}{4}$ ".

ON INCLINED OPERATIONS, OR AT SPEEDS IN EXCESS OF 150 STROKES PER MINUTE, THE GUIDE POST MUST ENGAGE THE BUSHING AT ALL TIMES AT LEAST $\frac{3}{4}$ " (THE ROTAINER® MUST BE ENGAGED BY THE GUIDE POST AND BUSHINGS AT ALL TIMES).

OPERATING CONDITIONS

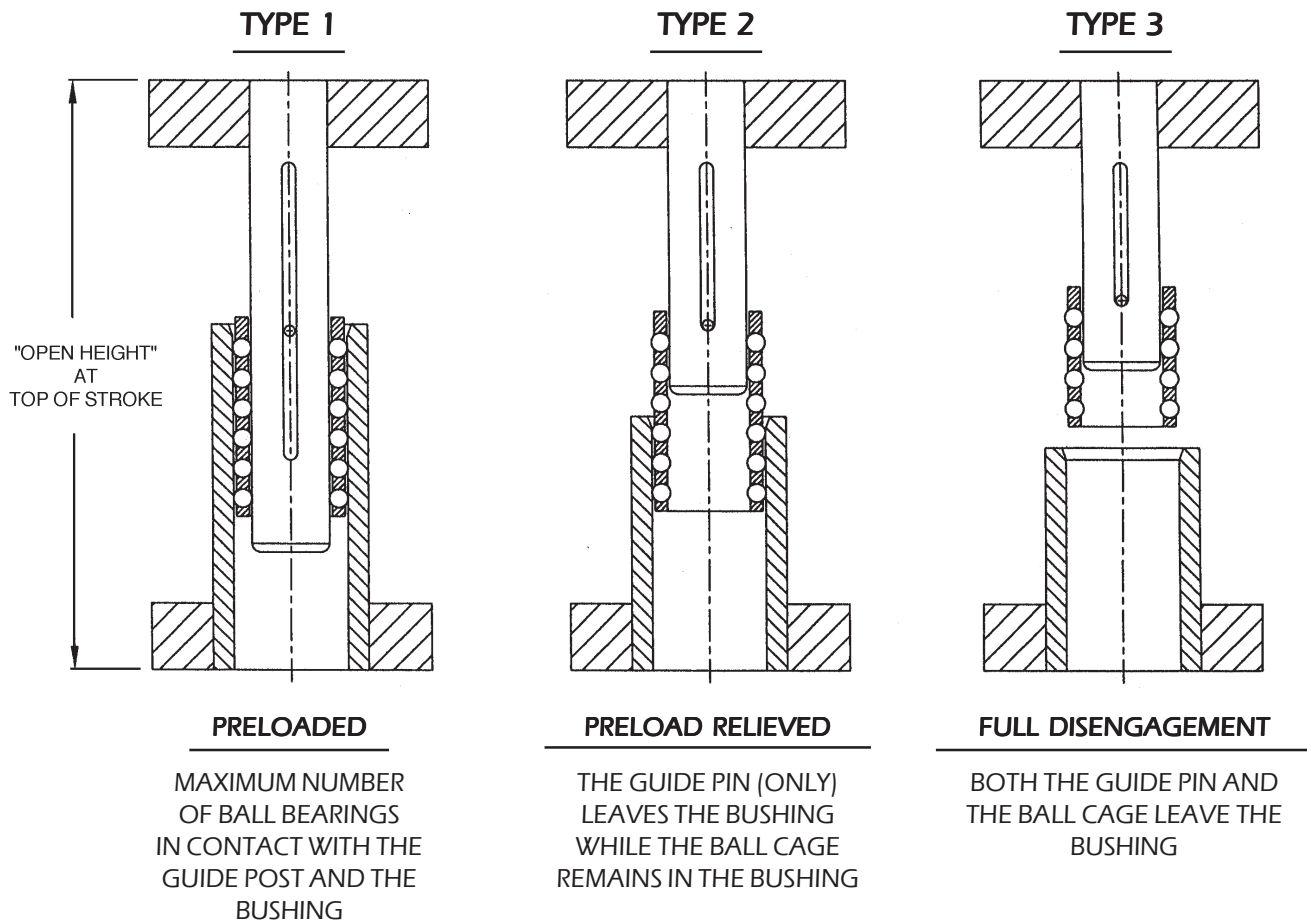

BALL-BEARING COMPONENT MAINTENANCE



Always use Ball-Lube® and Ball-Scrub® to keep ball-bearing components clean and running smooth.

Component maintenance is a serious business...

BALL-SCRUBB® removes heavy soils, dirt or grease from ball-bearing guide pin assemblies.

Just spray it on...wait 3 minutes... and spray again. Then blow off excess with compressed air.

BALL-SCRUBB® is an industrial strength cleaner with rust inhibitors, specially formulated to clean debris and grease from all types of ball-bearing assemblies.

BALL-LUBE®, when applied after BALL-SCRUBB®, locks out wear by chemically bonding to precision surfaces. It provides a tough, longlasting shield that protects against oxidation and rust.

BALL-LUBE® lubricates assemblies and gives them longtime protection against wear, oxidation and heat.

Spray liberally on ball-bearing assemblies.

TECHNICAL BULLETIN FOR BALL BEARING RETAINERS

Figure 1:
Two-Point Stake



Figure 2:
Orbital Stake



Figure 3:
Stake Stress – Two-Point

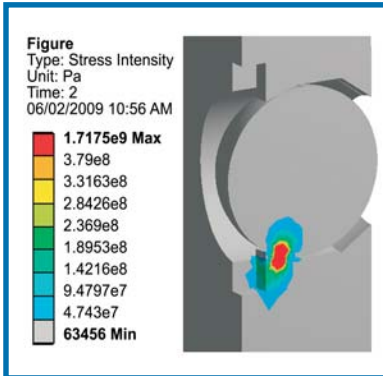
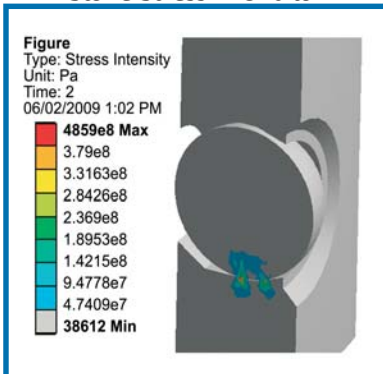

Figure 4:
Stake Stress – Orbital



BACKGROUND

Fatigue failures begin with a small crack in the material. The crack will develop at a point of discontinuity in the material, such as a change in cross section, a keyway, or a hole. Once a crack has developed, the stress-concentration effect becomes greater and the crack progresses more rapidly. As the stressed area decreases in size, the stress increases in magnitude until, finally, the remaining area fails suddenly.

The original **LEMPCO** ball staking design consisted of small rectangular indentations opposing each other at 180° around the ball (two-point staking); see Figure 1. This staking design consists of no/minimal radii, two full corners, and numerous material discontinuities, all allowing opportunities for crack propagation.

SOLUTION

We developed an improved ball staking method that consists of a complete circular indentation around the entire ball (orbital staking); see Figure 2. This design utilizes a uniform circular metal forming technique, with no sharp discontinuities in the material. The new method is intended to improve performance in regards to operational life cycle.

CONCLUSION

After an independent third party* ran a Finite Element Analysis, the following can be concluded:

- ◆ The peak stress and stress levels in general are much higher for the two-point stake than for the orbital stake. Figure 3 shows stress contours for the two-point stake, Figure 4 shows stress contours for the orbital stake.
- ◆ Due to the smaller volume of material in the two-point stake, high stresses exist in a significant portion of the indented material.
- ◆ The differences in stress levels and distribution imply that the fatigue life for the two-point stake will be much less than for the orbital stake, and with the lower stresses the orbital stake should improve the fatigue life.
- ◆ The differences in stress levels of the orbital stake design also imply that press speed can be increased with the orbital stake compared to the two-point stake.

* O'Donnell Consulting Engineers, Inc. <http://www.odonnellconsulting.com/fea.html>

LEMPCOLOY® PLAIN BEARING BUSHINGS

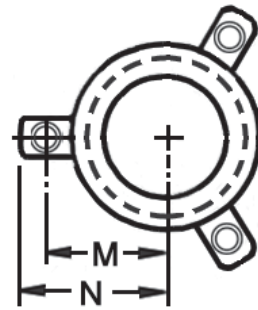
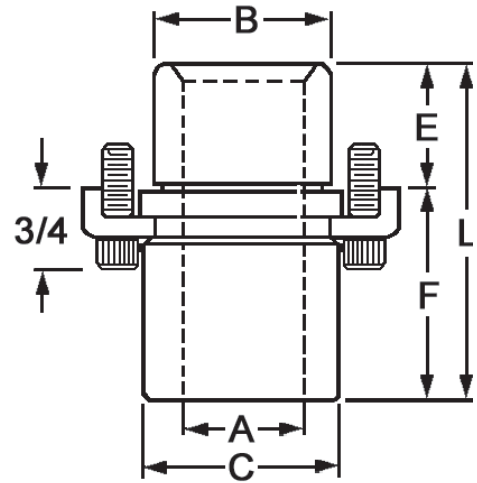

These unique hard coated aluminum bushings have the surface hardness of case hardened steel. An electrochemical process is used to increase the corrosion resistance of the bushings. As a result of this Hard Anodized process, they are also non-conductive, so they may be used for electrical discharge machining. They have a hard surface that is highly resistant to wear and not subject to magnetization. **These bushings are for clean room and EDM applications and should not be used in any stamping operation wherein a lot of contaminants are generated.**

Lempcoloy® bushings do not require lubrication and therefore are not provided with the conventional figure-eight oil grooves and fittings. While these bushings do not require lubrication, we recommend you apply a light mist of spindle oil prior to assembly and spray lightly prior to each press run.

Lempcoloy® bushings are designed to be installed by tap fitting to seat flush with the ground surface of the punch holder. They are assembled with toe clamps and screws. These bushings must not be pressed in or honed. These Lempcoloy® bushings will work well when used with Lamina plain bearing guide posts.

LEMPCOLOY® PLAIN BEARING BUSHINGS

Shoulder - Lempcoloy®

Catalog Number	Inside Dia. A Nom.	B	C	E	F	L	Radius	
							M	N
608-0409-LAM	1/2	0.812	15/16	5/8	1 1/2	2 1/8	0.697	1.010
608-0509-LAM	5/8	1.000	1 3/16	5/8	1 1/2	2 1/8	0.813	1.125
608-0611-LAM	3/4	1.125	1 5/16	7/8	1 3/4	2 5/8	0.875	1.188
608-0811-LAM	1	1.500	1 11/16	7/8	1 3/4	2 5/8	1.063	1.375
608-1013-LAM	1 1/4	1.750	1 15/16	1 1/8	2	3 1/8	1.219	1.531
608-1214-LAM	1 1/2	2.000	2 3/16	1 3/8	2	3 3/8	1.344	1.656
608-1414-LAM	1 3/4	2.250	2 1/2	1 3/8	2	3 3/8	1.500	1.813
608-1616-LAM	2	2.500	2 7/8	1 13/16	2	3 13/16	1.703	2.016
608-2018-LAM	2 1/2	3.250	3 5/8	1 13/16	2 1/2	4 5/16	2.078	2.391
608-2418-LAM	3	3.750	4 1/8	1 13/16	2 1/2	4 5/16	2.344	2.656

Short Shoulder - Lempcoloy®

Catalog Number	Inside Dia. A Nom.	B	C	E	F	L	Radius	
							M	N
607-0406-LAM	1/2	0.812	15/16	5/8	13/16	1 7/16	0.697	1.010
607-0506-LAM	5/8	1.000	1 3/16	5/8	13/16	1 7/16	0.813	1.125
607-0607-LAM	3/4	1.125	1 5/16	7/8	13/16	1 11/16	0.875	1.188
607-0807-LAM	1	1.500	1 11/16	7/8	13/16	1 11/16	1.063	1.375
607-1008-LAM	1 1/4	1.750	1 15/16	1 1/8	13/16	1 15/16	1.219	1.531
607-1209-LAM	1 1/2	2.000	2 3/16	1 3/8	13/16	2 3/16	1.344	1.656
607-1410-LAM	1 3/4	2.250	2 1/2	1 3/8	1	2 3/8	1.500	1.813
607-1612-LAM	2	2.500	2 7/8	1 13/16	1	2 13/16	1.703	2.016
607-2012-LAM	2 1/2	3.250	3 5/8	1 13/16	1	2 13/16	2.078	2.391
607-2412-LAM	3	3.750	4 1/8	1 13/16	1	2 13/16	2.344	2.656

Clamps for Assembly

Catalog Number	Inside Dia. A Nom.	Number of Clamps
899-9025	1	2
899-9125	1 1/4	3
899-9125	1 1/2	3
899-9125	1 3/4	4
899-9125	2	4
899-9125	2 1/2	4
899-9125	3	4

NOTE:

- ◆ For bushings with .002 over nominal ID to be used with a discontinued **LEMPCO** plain bearing guide post, remove the “-LAM” suffix from the part number.

ROTAINERS®

FOR METRIC BALL BEARING APPLICATIONS

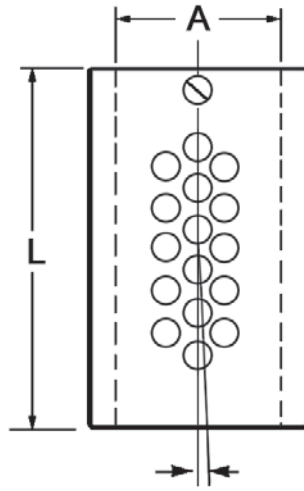

Radial bearing placement reduces wear and tracking.

Designed to rotate on the post, as well as maintain its vertical motion, **LEMPCO** ROTAINERS® were developed to greatly reduce the amount of tracking. The disengagement of the guide post from the bushing by 6.35mm at the top of the stroke will allow the ROTAINER® to rotate 360° on the guide post. The ROTAINER®, while still designed to track, (assuring a measurable amount of preload) will enable stampers to achieve high press production by reducing expensive replacement costs.

Nom. Post Diameter (mm) A	Length (mm) L	Catalog Number
19	39	367-19390
	51	367-19510
	65	367-19650
25	39	367-25390
	51	367-25510
	65	367-25650
32	62	367-32580
	75	367-32700
	87	367-32830
40	68	367-40650
	81	367-40770
	100	367-40960
44	75	367-44700
	87	367-44830
	113	367-44108
50	89	367-50830
	108	367-50102
	121	367-50114
63	100	367-63100
	140	367-63140
	178	367-63178
80	100	367-80100
	140	367-80140
	178	367-80178

NOTES:

- ◆ Diameters and lengths not listed are available by special order.
- ◆ The LAST length for each diameter shown in the table above should be used for general die set applications. Other lengths are for limited space and special applications.
- ◆ Under a preloaded condition, the ROTAINER® will only move vertically.

Rotainer® Slide Replacement with Screw Assembly		Number of Inserts
Nom. (mm)	Assembly Part No.	
19	06CLIP	1
25	08CLIP	1
32	10CLIP	1
40	12CLIP	1
44	14CLIP	1
50	16CLIP	2
63	20CLIP	2
80	24CLIP	2

PRECISION BALL BEARING RETAINERS

FOR METRIC BALL BEARING APPLICATIONS

Nom. Post Diameter (mm) A	Length (mm) L	Catalog Number
19	39	937-19390
	51	937-19510
	65	937-19650
25	39	937-25390
	51	937-25510
	65	937-25650
32	58	937-32580
	70	937-32700
	83	937-32830
40	65	937-40650
	77	937-40770
	96	937-40960
44	70	937-44700
	83	937-44830
	108	937-44108
50	83	937-50830
	102	937-50102
	114	937-50114
63	100	937-63100
	140	937-63140
	178	937-63178
80	100	937-80100
	140	937-80140
	178	937-80178

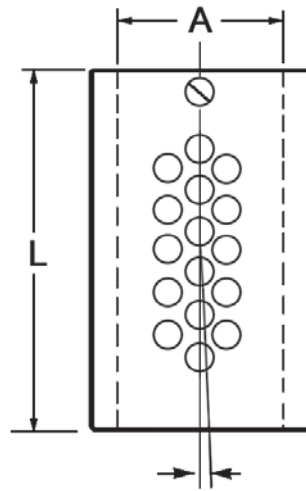

Radial bearing placement reduces wear and tracking.



LEMPCO Precision Ball Bearing Retainers possess resistance to normal wear and to lateral motion, are smooth in high speed operation and offer precise die register. They are keyed to the guide post slot with a set screw.

NOTE:

- ◆ The LAST length for each diameter shown in the table above should be used for general die set applications. Other lengths are for limited space and special applications.

DEMOUNTABLE STEEL GUIDE POST BUSHINGS

FOR METRIC BALL BEARING APPLICATIONS



LEMPCO Demountable Guide Post Bushings are manufactured from 52100 tool steel and precision machined. See pages 14 & 28 for mounting instructions.

Diameters and lengths not listed are available by special order.

Required clamps and screws are included.

Nom. Post Diameter	B	C	E	F	Radius		L	Catalog Numbers
					M	N		
25	43.956	51	30	25	31	40.5	55	966-25055
				30			60	966-25060
				35			65	966-25065
				40			70	966-25070
				45			75	966-25075
				50			80	966-25080
				55			85	966-25085
				60			90	966-25090
32	53.959	61	30	35	36.627	47.346	65	966-32065
				40			70	966-32070
				45			75	966-32075
				50			80	966-32080
				55			85	966-32085
				60			90	966-32090
				65			95	966-32095
				75			105	966-32105
				80			110	966-32110
				85			115	966-32115
				100			130	966-32130
				110			140	966-32140
40	64.960	72	35	40	42.190	52.908	75	966-40075
				45			80	966-40080
				50			85	966-40085
				55			90	966-40090
				60			95	966-40095
				65			100	966-40100
				75			110	966-40110
				80			115	966-40115
				85			120	966-40120
				90			125	966-40125
				100			135	966-40135
				105			140	966-40140
120	155	966-40155						

DEMOUNTABLE STEEL GUIDE POST BUSHINGS

FOR METRIC BALL BEARING APPLICATIONS

Nom. Post Diameter	B	C	E	F	Radius		L	Catalog Numbers
					M	N		
44	73.959	81	35	40	46.939	57.658	75	966-44075
				55			90	966-44090
				60			95	966-44095
				65			100	966-44100
				75			110	966-44110
				80			115	966-44115
				90			125	966-44125
				100			135	966-44135
				105			140	966-44140
				120			155	966-44155
				130			165	966-44165
				145			180	966-44180
				155			190	966-44190
				50			80.959	91
55	90	966-50090						
60	95	966-50095						
65	100	966-50100						
75	110	966-50110						
80	115	966-50115						
90	125	966-50125						
100	135	966-50135						
105	140	966-50140						
120	155	966-50155						
130	165	966-50165						
145	180	966-50180						
155	190	966-50190						
63	94.960	105	35		90	58.852		
				105	140		966-63140	
				120	155		966-63155	
				130	165		966-63165	
				145	180		966-63180	
				155	190		966-63190	
80	111.960	122	35	90	67.590	78.283	125	966-80125
				105			140	966-80140
				120			155	966-80155
				130			165	966-80165
				145			180	966-80180
				155			190	966-80190

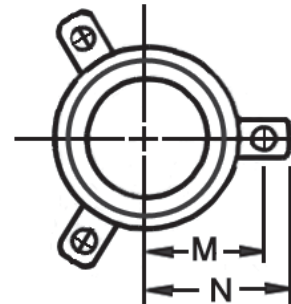
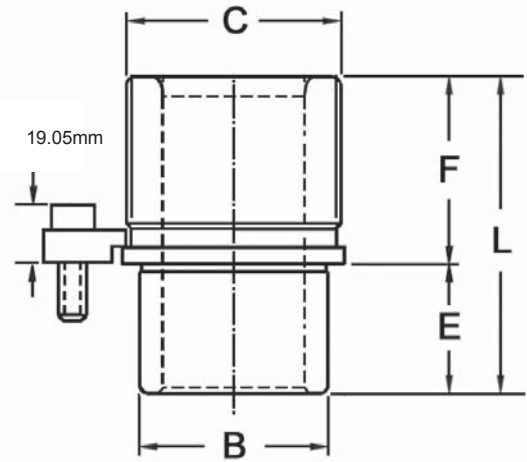

NOTES:

- ◆ The 966 Series product line is not stocked, but is available as a special order.
- ◆ The "C" dimension measurement is from the outside edge of the flange to the opposite outside edge.

PRESS FIT STEEL SLEEVE BUSHINGS

FOR METRIC BALL BEARING APPLICATIONS

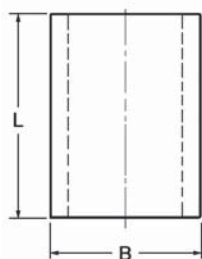

LEMPCO Press Fit Steel Sleeve Bushings are manufactured from 52100 tool steel and precision machined. The I.D. is ground and honed to an 8-12 RMS finish to minimize resistance to free action of the retainer/ Rotainer® bearings.

Nom. Post Diameter	B	L	Catalog Numbers
19	36.000	50	967-19500
		55	967-19550
		65	967-19650
		70	967-19700
		75	967-19750
		80	967-19800
		90	967-19900
		95	967-19950
		100	967-19100
		110	967-19110
25	44.000	75	967-25750
		80	967-25800
		90	967-25900
		95	967-25950
		100	967-25100
		105	967-25105
		115	967-25115
		120	967-25120
		125	967-25125
		140	967-25140
150	967-25150		
165	967-25165		
175	967-25175		

Nom. Post Diameter	B	L	Catalog Numbers
32	54.000	75	967-32750
		80	967-32800
		90	967-32900
		95	967-32950
		100	967-32100
		105	967-32105
		115	967-32115
		125	967-32125
		140	967-32140
		150	967-32150
		165	967-32165
		175	967-32175
		200	967-32200
		230	967-32230
40	65.000	100	967-40100
		105	967-40105
		115	967-40115
		120	967-40120
		125	967-40125
		135	967-40135
		140	967-40140
		150	967-40150
		165	967-40165
		175	967-40175
		190	967-40190
		200	967-40200
		215	967-40215
		230	967-40230
44	74.000	250	967-40250
		280	967-40280
		300	967-40300
		125	967-44125
		135	967-44135
		140	967-44140
		150	967-44150
		165	967-44165
		175	967-44175
		190	967-44190
		200	967-44200
		215	967-44215
		230	967-44230
		250	967-44250

Nom. Post Diameter	B	L	Catalog Numbers
44	74.000	280	967-44280
		300	967-44300
		330	967-44330
		125	967-50125
50	81.000	135	967-50135
		140	967-50140
		150	967-50150
		165	967-50165
		175	967-50175
		190	967-50190
		200	967-50200
		215	967-50215
		230	967-50230
		250	967-50250
		280	967-50280
		300	967-50300
		330	967-50330
		350	967-50350
63	95.000	150	967-63150
		165	967-63165
		175	967-63175
		190	967-63190
		200	967-63200
		215	967-63215
		230	967-63230
		250	967-63250
		280	967-63280
		300	967-63300
80	112.000	330	967-63330
		350	967-63350
		150	967-80150
		165	967-80165
		175	967-80175
		190	967-80190
		200	967-80200
		215	967-80215
		230	967-80230
		250	967-80250
280	967-80280		
300	967-80300		
330	967-80330		
350	967-80350		

STRAIGHT GUIDE POSTS

FOR METRIC BALL BEARING APPLICATIONS

LEMPCO Straight Guide Posts for ball bearing assemblies are manufactured from 52100 tool steel and precision ground. See pages 14 & 28 for mounting instructions.

Post Diameter A	Length L	Catalog Numbers
19	75	957-19750
	90	957-19900
	100	957-19100
	110	957-19110
	115	957-19115
	120	957-19120
	125	957-19125
	150	957-19150
25	100	957-25100
	110	957-25110
	115	957-25115
	120	957-25120
	125	957-25125
	135	957-25135
	140	957-25140
	145	957-25145
	150	957-25150
	165	957-25165
	175	957-25175
	190	957-25190
	200	957-25200
215	957-25215	
230	957-25230	
32	125	957-32125
	135	957-32135
	140	957-32140
	145	957-32145
	150	957-32150
	165	957-32165
	175	957-32175
	190	957-32190
	200	957-32200
	215	957-32215
	230	957-32230
	250	957-32250
	260	957-32260
	280	957-32280
300	957-32300	
40	125	957-40125
	135	957-40135
	140	957-40140
	145	957-40145
	150	957-40150

Post Diameter A	Length L	Catalog Numbers
40	165	957-40165
	175	957-40175
	190	957-40190
	200	957-40200
	215	957-40215
	230	957-40230
	240	957-40240
	250	957-40250
	265	957-40265
	280	957-40280
	290	957-40290
	300	957-40300
	44	125
135		957-44135
140		957-44140
145		957-44145
150		957-44150
165		957-44165
175		957-44175
190		957-44190
200		957-44200
215		957-44215
50	230	957-44230
	240	957-44240
	250	957-44250
	265	957-44265
	280	957-44280
	290	957-44290
	300	957-44300
	315	957-44315
	330	957-44330
	360	957-44360
50	150	957-50150
	165	957-50165
	175	957-50175
	190	957-50190
	200	957-50200
	215	957-50215
230	957-50230	
240	957-50240	

Post Diameter A	Length L	Catalog Numbers
50	250	957-50250
	265	957-50265
	280	957-50280
	290	957-50290
	300	957-50300
	315	957-50315
	330	957-50330
	360	957-50360
	380	957-50380
	400	957-50400
63	430	957-50430
	460	957-50460
	200	957-63200
	215	957-63215
	230	957-63230
	240	957-63240
	250	957-63250
	265	957-63265
	280	957-63280
	300	957-63300
80	315	957-63315
	330	957-63330
	360	957-63360
	380	957-63380
	430	957-63430
	500	957-63500
	200	957-80200
	215	957-80215
	230	957-80230
	250	957-80250
280	957-80280	
300	957-80300	
330	957-80330	
360	957-80360	
430	957-80430	
500	957-80500	

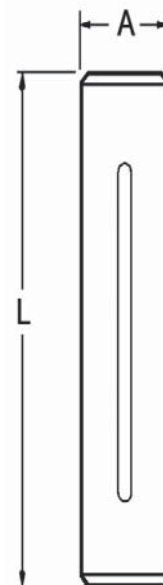

FLANGED DEMOUNTABLE GUIDE POSTS FOR METRIC BALL BEARING APPLICATIONS



Post	Diameter		Nominal Length			Catalog Numbers
	A	B	C	E	F	
24.953 24.940	33	24.953 24.940	30	60	90	958-25090
				70	100	958-25100
				80	110	958-25110
				85	115	958-25115
				90	120	958-25120
				95	125	958-25125
				105	135	958-25135
				110	140	958-25140
				115	145	958-25145
				120	150	958-25150
				135	165	958-25165
				145	175	958-25175
				160	190	958-25190
				170	200	958-25200
185	215	958-25215				
200	230	958-25230				
31.953 31.940	40	31.953 31.940	30	85	115	958-32115
				90	120	958-32120
				95	125	958-32125
				105	135	958-32135
				110	140	958-32140
				115	145	958-32145
				120	150	958-32150
				135	165	958-32165
				145	175	958-32175
				160	190	958-32190
				170	200	958-32200
				185	215	958-32215
				200	230	958-32230
				220	250	958-32250
250	280	958-32280				
270	300	958-32300				
39.952 39.939	48	39.952 39.939	36	79	115	958-40115
				84	120	958-40120
				89	125	958-40125
				99	135	958-40135
				104	140	958-40140
				109	145	958-40145
				114	150	958-40150
				129	165	958-40165
				139	175	958-40175
				154	190	958-40190
				164	200	958-40200
				179	215	958-40215
				194	230	958-40230
				204	240	958-40240
				214	250	958-40250
				224	260	958-40260
				244	280	958-40280
				254	290	958-40290
264	300	958-40300				
279	315	958-40315				
294	330	958-40330				
324	360	958-40360				
43.952 43.939	57	43.952 43.939	43	82	125	958-44125
				92	135	958-44135
				97	140	958-44140
				102	145	958-44145
				107	150	958-44150
				112	155	958-44155
122	165	958-44165				

LEMPCO Flanged Demountable Guide Posts for ball bearing assemblies are designed for those who prefer the convenience of a removable post to expedite die repairs. The post is tap fitted into the pin plate bore with the flange flush to the ground surface. See pages 14 & 28 for mounting instructions.

These Demountable Guide Posts are manufactured from 52100 tool steel.

Required clamps and screws are included.

FLANGED DEMOUNTABLE GUIDE POSTS

FOR METRIC BALL BEARING APPLICATIONS

Diameter			Nominal Length			Catalog Numbers
Post	Flange	C	E	F	L	
A	B					
43.952 43.939	57	43.952 43.939	43	132	175	958-44175
				147	190	958-44190
				157	200	958-44200
				172	215	958-44215
				187	230	958-44230
				197	240	958-44240
				207	250	958-44250
				217	260	958-44260
				237	280	958-44280
				247	290	958-44290
				257	300	958-44300
				272	315	958-44315
				287	330	958-44330
				317	360	958-44360
				337	380	958-44380
				387	430	958-44430
49.952 49.939	63	49.952 49.939	49	91	140	958-50140
				96	145	958-50145
				101	150	958-50150
				106	155	958-50155
				116	165	958-50165
				121	170	958-50170
				126	175	958-50175
				131	180	958-50180
				141	190	958-50190
				146	195	958-50195
				151	200	958-50200
				166	215	958-50215
				181	230	958-50230
				191	240	958-50240
				201	250	958-50250
				211	260	958-50260
				231	280	958-50280
				241	290	958-50290
				251	300	958-50300
				266	315	958-50315
281	330	958-50330				
311	360	958-50360				
331	380	958-50380				
351	400	958-50400				
381	430	958-50430				
411	460	958-50460				
62.952 62.939	76	62.952 62.939	49	151	200	958-63200
				166	215	958-63215
				181	230	958-63230
				201	250	958-63250
				231	280	958-63280
				251	300	958-63300
				281	330	958-63330
				311	360	958-63360
				381	430	958-63430
				451	500	958-63500
79.952 79.939	93	79.952 79.939	62	138	200	958-80200
				153	215	958-80215
				168	230	958-80230
				188	250	958-80250
				218	280	958-80280
				238	300	958-80300
				268	330	958-80330
				298	360	958-80360
				368	430	958-80430
				438	500	958-80500

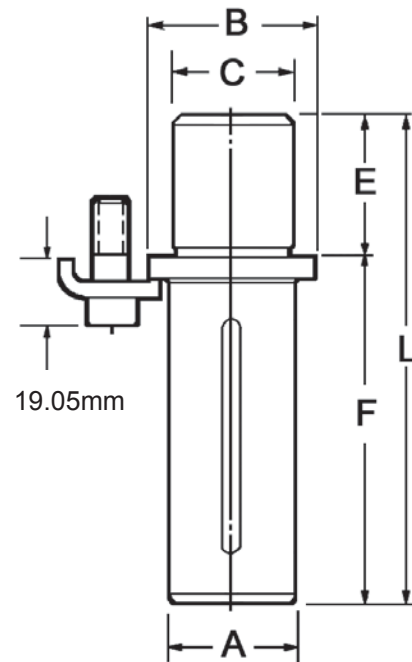

BALL BEARING ENGINEERING DATA - METRIC

BORING PROCEDURES AND DIMENSIONS

Holes for **LEMPCO** Ball Bearing Guide Posts and Bushings should be jig bored for best results. The punch holder and dieholder should be clamped together and bored in one setup in order to maintain dead center alignment between the upper and lower bores. If it is not possible to bore in this manner, a tolerance of $\pm 0.0127\text{mm}$ between centers (see illustration) must be held. Bores should be smooth and free from tool marks to provide proper bearing area for the guide post and bushing.

Dieholder bores must be perpendicular to the surface of the dieholder which will back up the die. The bottom surface of the dieholder must be parallel to the die backup surface. The punch holder bores also must be perpendicular to the surface which will back up the punches, and the top surface parallel to the punch backup surface.

Break the corners of the bored holes to a generous chamfer. On sets with a symmetrical profile one pin and bushing should be offset to prevent accidental reversing of the punch holder during assembly.

All of the **LEMPCO** Ball Bearing Guide Posts, Bushings Retainers and Rotainers are completely interchangeable without the need for select fitting, and if mounted in accordance with boring and assembly instructions given on this and on page 14 do not require any grinding, honing, lapping, or any other modifications of any kind. Please note the dimensions given in the following table. Our experience over many years proves that these are optimum dimensions. Variations must be avoided.

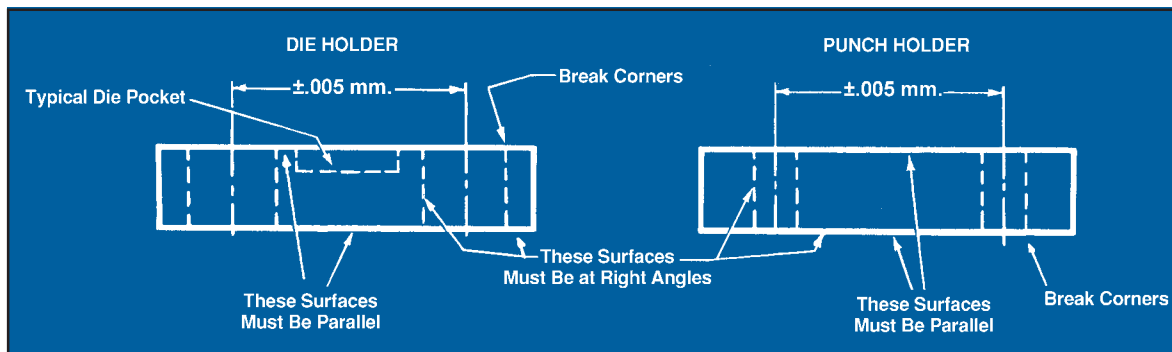

BORE CHART – BALL BEARING COMPONENTS (METRIC)

Nominal Guide Post Diameter	#957-SERIES STRAIGHT GUIDE PIN (PRESS FIT)	#958-SERIES DEMOUNTABLE GUIDE PIN (TAP FIT)	#967-SERIES STRAIGHT SLEEVE BUSHING (PRESS FIT)	#966-SERIES DEMOUNTABLE SHOULDER BUSHING (TAP FIT)
	BORE SIZE	BORE SIZE	BORE SIZE	BORE SIZE
	19mm	18.977 / 18.946	N/A	36.005 / 35.992
25mm	24.979 / 24.948	24.966 / 24.953	44.006 / 43.993	43.972 / 43.960
32mm	31.966 / 31.941	32.343 / 32.331	54.005 / 53.993	53.972 / 53.960
40mm	39.967 / 39.942	40.436 / 40.424	65.006 / 64.994	64.973 / 64.961
44mm	43.968 / 43.942	44.484 / 44.471	74.005 / 73.993	73.972 / 73.960
50mm	49.967 / 49.950	50.554 / 50.542	81.006 / 80.993	81.227 / 80.960
63mm	62.962 / 62.939	63.707 / 63.695	95.006 / 94.993	94.973 / 94.960
80mm	79.960 / 79.937	80.908 / 80.896	112.006 / 111.994	111.973 / 111.961

(UNLESS OTHERWISE NOTED, ALL DIMENSIONS ARE IN MILLIMETERS)

DIE SPRINGS PRODUCT FEATURES

- ◆ Same day shipments – we stock them so you don't have to
- ◆ Inch sizes manufactured to industry standard colors
- ◆ Reliable, trouble-free performance
- ◆ Manufactured in an ISO 9001:2000 certified facility
- ◆ Manufactured from spring-quality Chromium Silicon alloy, high-tensile strength steel in accordance with ASTM A1000-99 specifications
- ◆ Optimal rectangular wire design

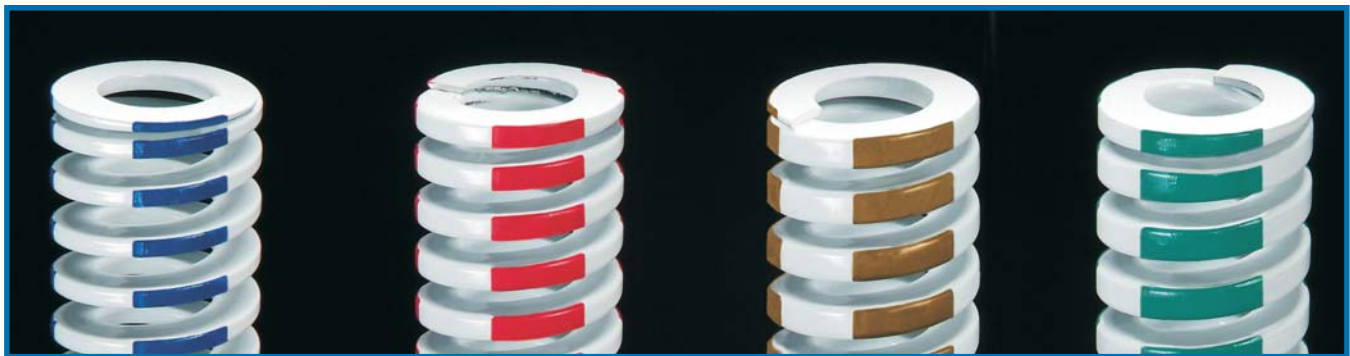

MEDIUM DUTY
Color Coded
Blue Stripe

MEDIUM HEAVY DUTY
Color Coded
Red Stripe

HEAVY DUTY
Color Coded
Gold Stripe

EXTRA HEAVY DUTY
Color Coded
Green Stripe

CUSTOM SPRINGS

A custom spring is any spring that has:

- ◆ Unique physical attributes
 - Special wire material, plating or paint
 - Custom free lengths, diameters, solid heights, rates, number of coils or custom loads at a given deflection
- ◆ Critical tolerances
- ◆ Specific inspection or certification requirements
 - Military specifications
 - 100% inspection of critical characteristics
- ◆ Statistical reports
- ◆ Computer controlled multi-point tests



MEDIUM DUTY DIE SPRINGS

COLOR CODED BLUE STRIPE

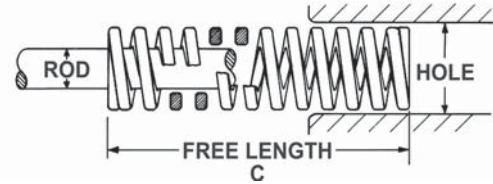
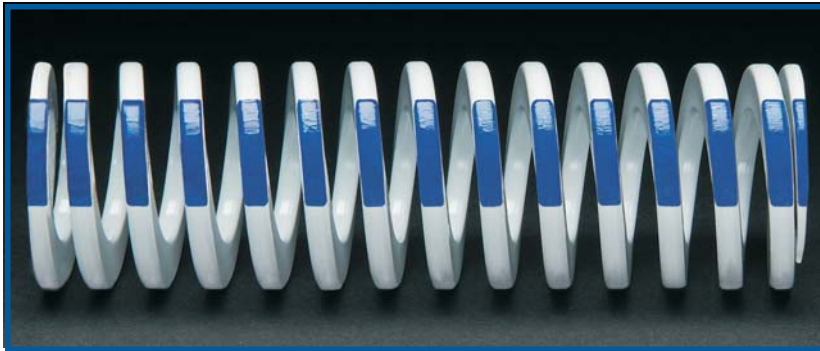

Hole Diam. (in)	Rod Diam. (in)	Free Length (in)	Wire Size (in)	CATALOG NUMBER	Pounds @ 1/10 inch defl.	Total Deflection Recommended for Long Life (25% of C)		Total Deflection Recommended for Avg. Life (35% of C)		Maximum Operating Deflection (40% of C)		Max. Defl. (45%)* (in)
						Load lbs.	Defl. in.	Load lbs.	Defl. in.	Load lbs.	Defl. in.	
3/8	3/16	1.00	0.040 X 0.070	9-0604-1	6.2	15.5	0.25	21.7	0.35	24.8	0.40	0.45
		1.25		9-0605-1	5.3	16.6	0.31	23.2	0.44	26.5	0.50	0.56
		1.50		9-0606-1	4.2	15.6	0.38	21.8	0.53	24.9	0.60	0.68
		1.75		9-0607-1	3.5	15.3	0.44	21.4	0.61	24.5	0.70	0.79
		2.00		9-0608-1	2.9	14.5	0.50	20.3	0.70	23.2	0.80	0.90
		2.50		9-0610-1	2.4	15.3	0.63	21.4	0.88	24.4	1.00	1.13
		3.00		9-0612-1	2.1	15.8	0.75	22.1	1.05	25.2	1.20	1.35
		12.00	9-0648-1	0.6	16.8	3.00	23.5	4.20	26.9	4.80	5.40	
1/2	9/32	1.00	0.052 X 0.095	9-0804-1	10.7	26.8	0.25	37.5	0.35	42.8	0.40	0.45
		1.25		9-0805-1	8.2	25.6	0.31	35.9	0.44	41.0	0.50	0.56
		1.50		9-0806-1	6.8	25.5	0.38	35.7	0.53	40.8	0.60	0.68
		1.75		9-0807-1	6.0	26.3	0.44	36.8	0.61	42.0	0.70	0.79
		2.00		9-0808-1	5.3	26.5	0.50	37.1	0.70	42.4	0.80	0.90
		2.50		9-0810-1	4.3	26.9	0.63	37.6	0.88	43.0	1.00	1.13
		3.00		9-0812-1	3.4	25.5	0.75	35.7	1.05	40.8	1.20	1.35
		3.50		9-0814-1	2.9	25.4	0.88	35.5	1.23	40.6	1.40	1.58
		4.50		9-0818-1	2.4	27.0	1.13	37.8	1.58	43.2	1.80	2.03
		5.50		9-0822-1	2.0	27.5	1.38	38.5	1.93	44.0	2.20	2.48
		6.50		9-0826-1	1.4	22.8	1.63	31.9	2.28	36.4	2.60	2.93
7.50	9-0830-1	1.2	22.5	1.88	31.5	2.63	36.0	3.00	3.38			
		12.00	9-0848-1	0.7	21.0	3.00	29.4	4.20	33.6	4.80	5.40	
5/8	11/32	1.00	0.068 X 0.117	9-1004-1	17.0	42.5	0.25	59.5	0.35	68.0	0.40	0.45
		1.25		9-1005-1	13.0	40.6	0.31	56.9	0.44	65.0	0.50	0.56
		1.50		9-1006-1	11.1	41.6	0.38	58.3	0.53	66.6	0.60	0.68
		1.75		9-1007-1	9.6	42.0	0.44	58.8	0.61	67.2	0.70	0.79
		2.00		9-1008-1	8.8	44.0	0.50	61.6	0.70	70.4	0.80	0.90
		2.50		9-1010-1	6.3	39.4	0.63	55.1	0.88	63.0	1.00	1.13
		3.00		9-1012-1	5.6	42.0	0.75	58.8	1.05	67.2	1.20	1.35
		3.50		9-1014-1	4.8	42.0	0.88	58.8	1.23	67.2	1.40	1.58
		4.00		9-1016-1	4.4	44.0	1.00	61.6	1.40	70.4	1.60	1.80
					12.00	9-1048-1	1.5	45.6	3.00	63.8	4.20	73.0
3/4	3/8	1.00	0.085 X 0.155	9-1204-1	31.8	79.5	0.25	111.3	0.35	127.2	0.40	0.45
		1.25		9-1205-1	25.6	80.0	0.31	112.0	0.44	128.0	0.50	0.56
		1.50		9-1206-1	20.0	75.0	0.38	105.0	0.53	120.0	0.60	0.68
		1.75		9-1207-1	17.6	77.0	0.44	107.8	0.61	123.2	0.70	0.79
		2.00		9-1208-1	14.4	72.0	0.50	100.8	0.70	115.2	0.80	0.90
		2.50		9-1210-1	12.0	75.0	0.63	105.0	0.88	120.0	1.00	1.13
		3.00		9-1212-1	9.6	72.0	0.75	100.8	1.05	115.2	1.20	1.35
		3.50		9-1214-1	8.0	70.0	0.88	98.0	1.23	112.0	1.40	1.58
		4.00		9-1216-1	7.2	72.0	1.00	100.8	1.40	115.2	1.60	1.80
		4.50		9-1218-1	6.4	72.0	1.13	100.8	1.58	115.2	1.80	2.03
		5.00		9-1220-1	6.0	75.0	1.25	105.0	1.75	120.0	2.00	2.25
		5.50		9-1222-1	5.5	75.6	1.38	105.9	1.93	121.0	2.20	2.48
		6.00		9-1224-1	5.0	75.0	1.50	105.0	2.10	120.0	2.40	2.70
		6.50		9-1226-1	4.5	73.1	1.63	102.4	2.28	117.0	2.60	2.93
		7.50		9-1230-1	3.8	71.3	1.88	99.8	2.63	114.0	3.00	3.38
		12.00	9-1248-1	2.4	72.0	3.00	100.8	4.20	115.2	4.80	5.40	

* NOTE: For design purposes only. We do not recommend deflecting a spring to maximum deflection.

INCH STANDARD

COLOR CODED BLUE STRIPE

Hole Diam. (in)	Rod Diam. (in)	Free Length (in)	Wire Size (in)	CATALOG NUMBER	Pounds @ 1/10 inch defl.	Total Deflection Recommended for Long Life (25% of C)		Total Deflection Recommended for Avg. Life (35% of C)		Maximum Operating Deflection (40% of C)		Max. Defl. (45%)* (in)
						Load lbs.	Defl. in.	Load lbs.	Defl. in.	Load lbs.	Defl. in.	
1	1/2	1.00	0.105 X 0.212	9-1604-1	55.0	137.5	0.25	192.5	0.35	220.0	0.40	0.45
		1.25		9-1605-1	45.0	140.6	0.31	196.9	0.44	225.0	0.50	0.56
		1.50		9-1606-1	35.4	132.8	0.38	185.9	0.53	212.4	0.60	0.68
		1.75		9-1607-1	30.0	131.3	0.44	183.8	0.61	210.0	0.70	0.79
		2.00		9-1608-1	26.0	130.0	0.50	182.0	0.70	208.0	0.80	0.90
		2.50		9-1610-1	20.2	126.3	0.63	176.8	0.88	202.0	1.00	1.13
		3.00		9-1612-1	16.5	123.8	0.75	173.3	1.05	198.0	1.20	1.35
		3.50		9-1614-1	15.0	131.3	0.88	183.8	1.23	210.0	1.40	1.58
		4.00		9-1616-1	12.0	120.0	1.00	168.0	1.40	192.0	1.60	1.80
		4.50		9-1618-1	10.5	118.1	1.13	165.4	1.58	189.0	1.80	2.03
		5.00		9-1620-1	9.6	120.0	1.25	168.0	1.75	192.0	2.00	2.25
		5.50		9-1622-1	8.8	121.0	1.38	169.4	1.93	193.6	2.20	2.48
		6.00		9-1624-1	8.0	120.0	1.50	168.0	2.10	192.0	2.40	2.70
		7.00		9-1628-1	7.2	126.0	1.75	176.4	2.45	201.6	2.80	3.15
8.00	9-1632-1	6.0	120.0	2.00	168.0	2.80	192.0	3.20	3.60			
12.00	9-1648-1	4.0	120.0	3.00	168.0	4.20	192.0	4.80	5.40			
1 1/4	5/8	1.50	0.125 X 0.270	9-2006-1	51.0	191.3	0.38	267.8	0.53	306.0	0.60	0.68
		1.75		9-2007-1	42.4	185.5	0.44	259.7	0.61	296.8	0.70	0.79
		2.00		9-2008-1	36.0	180.0	0.50	252.0	0.70	288.0	0.80	0.90
		2.50		9-2010-1	28.8	180.0	0.63	252.0	0.88	288.0	1.00	1.13
		3.00		9-2012-1	24.0	180.0	0.75	252.0	1.05	288.0	1.20	1.35
		3.50		9-2014-1	20.0	175.0	0.88	245.0	1.23	280.0	1.40	1.58
		4.00		9-2016-1	17.6	176.0	1.00	246.4	1.40	281.6	1.60	1.80
		4.50		9-2018-1	16.0	180.0	1.13	252.0	1.58	288.0	1.80	2.03
		5.00		9-2020-1	13.6	170.0	1.25	238.0	1.75	272.0	2.00	2.25
		5.50		9-2022-1	12.8	176.0	1.38	246.4	1.93	281.6	2.20	2.48
		6.00		9-2024-1	12.0	180.0	1.50	252.0	2.10	288.0	2.40	2.70
		7.00		9-2028-1	10.4	182.0	1.75	254.8	2.45	291.2	2.80	3.15
		8.00		9-2032-1	8.8	176.0	2.00	246.4	2.80	281.6	3.20	3.60
		10.00		9-2040-1	7.2	180.0	2.50	252.0	3.50	288.0	4.00	4.50
12.00	9-2048-1	6.0	180.0	3.00	252.0	4.20	288.0	4.80	5.40			
1 1/2	3/4	2.00	0.158 X 0.315	9-2408-1	54.7	273.5	0.50	382.9	0.70	437.6	0.80	0.90
		2.50		9-2410-1	44.7	279.4	0.63	391.1	0.88	447.0	1.00	1.13
		3.00		9-2412-1	36.0	270.0	0.75	378.0	1.05	432.0	1.20	1.35
		3.50		9-2414-1	30.0	262.5	0.88	367.5	1.23	420.0	1.40	1.58
		4.00		9-2416-1	27.0	270.0	1.00	378.0	1.40	432.0	1.60	1.80
		4.50		9-2418-1	23.0	258.8	1.13	362.3	1.58	414.0	1.80	2.03
		5.00		9-2420-1	21.0	262.5	1.25	367.5	1.75	420.0	2.00	2.25
		5.50		9-2422-1	18.5	254.4	1.38	356.1	1.93	407.0	2.20	2.48
		6.00		9-2424-1	17.0	255.0	1.50	357.0	2.10	408.0	2.40	2.70
		7.00		9-2428-1	14.5	253.8	1.75	355.3	2.45	406.0	2.80	3.15
		8.00		9-2432-1	12.8	256.0	2.00	358.4	2.80	409.6	3.20	3.60
		10.00		9-2440-1	10.0	250.0	2.50	350.0	3.50	400.0	4.00	4.50
		12.00		9-2448-1	8.2	246.0	3.00	344.4	4.20	393.6	4.80	5.40
		2		1	2.50	0.215 X 0.445	9-3210-1	100.0	625.0	0.63	875.0	0.88
3.00	9-3212-1		83.0		622.5		0.75	871.5	1.05	996.0	1.20	1.35
3.50	9-3214-1		65.8		575.8		0.88	806.1	1.23	921.2	1.40	1.58
4.00	9-3216-1		60.0		600.0		1.00	840.0	1.40	960.0	1.60	1.80
4.50	9-3218-1		53.0		596.3		1.13	834.8	1.58	954.0	1.80	2.03
5.00	9-3220-1		47.0		587.5		1.25	822.5	1.75	940.0	2.00	2.25
5.50	9-3222-1		39.8		547.3		1.38	766.2	1.93	875.6	2.20	2.48
6.00	9-3224-1		39.0		585.0		1.50	819.0	2.10	936.0	2.40	2.70
7.00	9-3228-1		31.6		553.0		1.75	774.2	2.45	884.8	2.80	3.15
8.00	9-3232-1		28.5		570.0		2.00	798.0	2.80	912.0	3.20	3.60
10.00	9-3240-1		20.8		520.0		2.50	728.0	3.50	832.0	4.00	4.50
12.00	9-3248-1	17.5	525.0	3.00	735.0	4.20	840.0	4.80	5.40			

* NOTE: For design purposes only. We do not recommend deflecting a spring to maximum deflection.

MEDIUM HEAVY DUTY DIE SPRINGS

COLOR CODED RED STRIPE

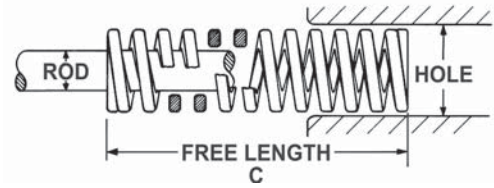
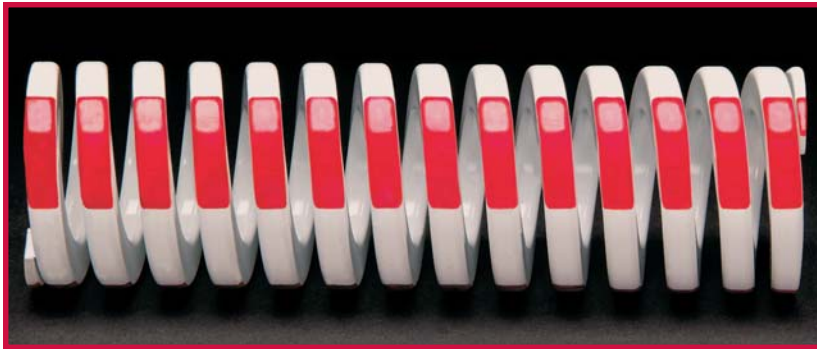

Hole Diam. (in)	Rod Diam. (in)	Free Length (in)	Wire Size (in)	CATALOG NUMBER	Pounds @ 1/10 inch defl.	Total Deflection Recommended for Long Life (20% of C)		Total Deflection Recommended for Avg. Life (25% of C)		Maximum Operating Deflection (35% of C)		Max. Defl. (37%)* (in)
						Load lbs.	Defl. in.	Load lbs.	Defl. in.	Load lbs.	Defl. in.	
3/8	3/16	1.00	0.045 X 0.070	9-0604-2	9.0	18.0	0.20	22.5	0.25	31.5	0.35	0.37
		1.25		9-0605-2	7.3	18.3	0.25	22.8	0.31	31.9	0.44	0.46
		1.50		9-0606-2	6.7	20.1	0.30	25.1	0.38	35.2	0.53	0.56
		1.75		9-0607-2	5.7	20.0	0.35	24.9	0.44	34.9	0.61	0.65
		2.00		9-0608-2	5.0	20.0	0.40	25.0	0.50	35.0	0.70	0.74
		2.50		9-0610-2	4.0	20.0	0.50	25.0	0.63	35.0	0.88	0.93
		3.00		9-0612-2	3.0	18.0	0.60	22.5	0.75	31.5	1.05	1.11
		12.00		9-0648-2	0.8	19.2	2.40	24.0	3.00	33.6	4.20	4.44
1/2	9/32	1.00	0.060 X 0.095	9-0804-2	16.6	33.2	0.20	41.5	0.25	58.1	0.35	0.37
		1.25		9-0805-2	13.0	32.5	0.25	40.6	0.31	56.9	0.44	0.46
		1.50		9-0806-2	9.9	29.7	0.30	37.1	0.38	52.0	0.53	0.56
		1.75		9-0807-2	8.5	29.8	0.35	37.2	0.44	52.1	0.61	0.65
		2.00		9-0808-2	7.5	30.0	0.40	37.5	0.50	52.5	0.70	0.74
		2.50		9-0810-2	6.0	30.0	0.50	37.5	0.63	52.5	0.88	0.93
		3.00		9-0812-2	5.5	33.0	0.60	41.3	0.75	57.8	1.05	1.11
		3.50		9-0814-2	4.0	28.0	0.70	35.0	0.88	49.0	1.23	1.30
		4.00		9-0848-2	1.2	28.8	2.40	36.0	3.00	50.4	4.20	4.44
		5/8		11/32	1.00	0.086 X 0.112	9-1004-2	30.0	60.0	0.20	75.0	0.25
1.25	9-1005-2		21.5		53.8		0.25	67.2	0.31	94.1	0.44	0.46
1.50	9-1006-2		19.2		57.6		0.30	72.0	0.38	100.8	0.53	0.56
1.75	9-1007-2		16.8		58.8		0.35	73.5	0.44	102.9	0.61	0.65
2.00	9-1008-2		14.8		59.2		0.40	74.0	0.50	103.6	0.70	0.74
2.50	9-1010-2		11.5		57.5		0.50	71.9	0.63	100.6	0.88	0.93
3.00	9-1012-2		10.0		60.0		0.60	75.0	0.75	105.0	1.05	1.11
3.50	9-1014-2		8.5		59.5		0.70	74.4	0.88	104.1	1.23	1.30
4.00	9-1016-2		7.6		60.8		0.80	76.0	1.00	106.4	1.40	1.48
12.00	9-1048-2		2.6		62.4		2.40	78.0	3.00	109.2	4.20	4.44
3/4	3/8	1.00	0.100 X 0.155	9-1204-2	50.0	100.0	0.20	125.0	0.25	175.0	0.35	0.37
		1.25		9-1205-2	38.0	95.0	0.25	118.8	0.31	166.3	0.44	0.46
		1.50		9-1206-2	32.0	96.0	0.30	120.0	0.38	168.0	0.53	0.56
		1.75		9-1207-2	28.5	99.8	0.35	124.7	0.44	174.6	0.61	0.65
		2.00		9-1208-2	24.8	99.2	0.40	124.0	0.50	173.6	0.70	0.74
		2.50		9-1210-2	19.2	96.0	0.50	120.0	0.63	168.0	0.88	0.93
		3.00		9-1212-2	14.4	86.4	0.60	108.0	0.75	151.2	1.05	1.11
		3.50		9-1214-2	12.8	89.6	0.70	112.0	0.88	156.8	1.23	1.30
		4.00		9-1216-2	12.0	96.0	0.80	120.0	1.00	168.0	1.40	1.48
		4.50		9-1218-2	11.0	99.0	0.90	123.8	1.13	173.3	1.58	1.67
		5.00		9-1220-2	9.0	90.0	1.00	112.5	1.25	157.5	1.75	1.85
		5.50		9-1222-2	8.0	88.0	1.10	110.0	1.38	154.0	1.93	2.04
		6.00		9-1224-2	7.5	90.0	1.20	112.5	1.50	157.5	2.10	2.22
		12.00		9-1248-2	3.6	86.4	2.40	108.0	3.00	151.2	4.20	4.44

* NOTE: For design purposes only. We do not recommend deflecting a spring to maximum deflection.

INCH STANDARD

COLOR CODED RED STRIPE

Hole Diam. (in)	Rod Diam. (in)	Free Length (in)	Wire Size (in)	CATALOG NUMBER	Pounds @ 1/10 inch defl.	Total Deflection Recommended for Long Life (20% of C)		Total Deflection Recommended for Avg. Life (25% of C)		Maximum Operating Deflection (35% of C)		Max. Defl. (37%)* (in)
						Load lbs.	Defl. in.	Load lbs.	Defl. in.	Load lbs.	Defl. in.	
1	1/2	1.00	0.125 X 0.214	9-1604-2	76.0	152.0	0.20	190.0	0.25	266.0	0.35	0.37
		1.25		9-1605-2	62.4	156.0	0.25	195.0	0.31	273.0	0.44	0.46
		1.50		9-1606-2	49.6	148.8	0.30	186.0	0.38	260.4	0.53	0.56
		1.75		9-1607-2	44.0	154.0	0.35	192.5	0.44	269.5	0.61	0.65
		2.00		9-1608-2	40.0	160.0	0.40	200.0	0.50	280.0	0.70	0.74
		2.50		9-1610-2	31.0	155.0	0.50	193.8	0.63	271.3	0.88	0.93
		3.00		9-1612-2	25.0	150.0	0.60	187.5	0.75	262.5	1.05	1.11
		3.50		9-1614-2	21.6	151.2	0.70	189.0	0.88	264.6	1.23	1.30
		4.00		9-1616-2	18.4	147.2	0.80	184.0	1.00	257.6	1.40	1.48
		4.50		9-1618-2	17.0	153.0	0.90	191.3	1.13	267.8	1.58	1.67
		5.00		9-1620-2	14.4	144.0	1.00	180.0	1.25	252.0	1.75	1.85
		5.50		9-1622-2	12.8	140.8	1.10	176.0	1.38	246.4	1.93	2.04
6.00	9-1624-2	12.0	144.0	1.20	180.0	1.50	252.0	2.10	2.22			
7.00	9-1628-2	10.0	140.0	1.40	175.0	1.75	245.0	2.45	2.59			
8.00	9-1632-2	8.8	140.8	1.60	176.0	2.00	246.4	2.80	2.96			
12.00	9-1648-2	6.2	148.8	2.40	186.0	3.00	260.4	4.20	4.44			
1 1/4	5/8	1.50	0.165 X 0.270	9-2006-2	113.4	340.2	0.30	425.3	0.38	595.4	0.53	0.56
		1.75		9-2007-2	94.5	330.8	0.35	413.4	0.44	578.8	0.61	0.65
		2.00		9-2008-2	81.0	324.0	0.40	405.0	0.50	567.0	0.70	0.74
		2.50		9-2010-2	62.4	312.0	0.50	390.0	0.63	546.0	0.88	0.93
		3.00		9-2012-2	51.2	307.2	0.60	384.0	0.75	537.6	1.05	1.11
		3.50		9-2014-2	43.5	304.5	0.70	380.6	0.88	532.9	1.23	1.30
		4.00		9-2016-2	36.8	294.4	0.80	368.0	1.00	515.2	1.40	1.48
		4.50		9-2018-2	32.0	288.0	0.90	360.0	1.13	504.0	1.58	1.67
		5.00		9-2020-2	29.0	290.0	1.00	362.5	1.25	507.5	1.75	1.85
		5.50		9-2022-2	26.4	290.4	1.10	363.0	1.38	508.2	1.93	2.04
		6.00		9-2024-2	25.0	300.0	1.20	375.0	1.50	525.0	2.10	2.22
		7.00		9-2028-2	20.0	280.0	1.40	350.0	1.75	490.0	2.45	2.59
8.00	9-2032-2	18.4	294.4	1.60	368.0	2.00	515.2	2.80	2.96			
10.00	9-2040-2	14.5	290.0	2.00	362.5	2.50	507.5	3.50	3.70			
12.00	9-2048-2	12.1	290.4	2.40	363.0	3.00	508.2	4.20	4.44			
1 1/2	3/4	2.00	0.191 X 0.320	9-2408-2	104.0	416.0	0.40	520.0	0.50	728.0	0.70	0.74
		2.50		9-2410-2	81.5	407.5	0.50	509.4	0.63	713.1	0.88	0.93
		3.00		9-2412-2	62.4	374.4	0.60	468.0	0.75	655.2	1.05	1.11
		3.50		9-2414-2	52.8	369.6	0.70	462.0	0.88	646.8	1.23	1.30
		4.00		9-2416-2	47.3	378.4	0.80	473.0	1.00	662.2	1.40	1.48
		4.50		9-2418-2	41.6	374.4	0.90	468.0	1.13	655.2	1.58	1.67
		5.00		9-2420-2	36.8	368.0	1.00	460.0	1.25	644.0	1.75	1.85
		5.50		9-2422-2	33.6	369.6	1.10	462.0	1.38	646.8	1.93	2.04
		6.00		9-2424-2	30.4	364.8	1.20	456.0	1.50	638.4	2.10	2.22
		7.00		9-2428-2	26.4	369.6	1.40	462.0	1.75	646.8	2.45	2.59
		8.00		9-2432-2	22.0	352.0	1.60	440.0	2.00	616.0	2.80	2.96
		10.00		9-2440-2	17.6	352.0	2.00	440.0	2.50	616.0	3.50	3.70
12.00	9-2448-2	14.4	345.6	2.40	432.0	3.00	604.8	4.20	4.44			
2	1	2.50	0.235 X 0.440	9-3210-2	118.4	592.0	0.50	740.0	0.63	1036.0	0.88	0.93
		3.00		9-3212-2	96.0	576.0	0.60	720.0	0.75	1008.0	1.05	1.11
		3.50		9-3214-2	80.0	560.0	0.70	700.0	0.88	980.0	1.23	1.30
		4.00		9-3216-2	66.4	531.2	0.80	664.0	1.00	929.6	1.40	1.48
		4.50		9-3218-2	60.0	540.0	0.90	675.0	1.13	945.0	1.58	1.67
		5.00		9-3220-2	55.1	551.0	1.00	688.8	1.25	964.3	1.75	1.85
		5.50		9-3222-2	49.7	546.7	1.10	683.4	1.38	956.7	1.93	2.04
		6.00		9-3224-2	45.3	543.6	1.20	679.5	1.50	951.3	2.10	2.22
		7.00		9-3228-2	38.5	539.0	1.40	673.8	1.75	943.3	2.45	2.59
		8.00		9-3232-2	33.5	536.0	1.60	670.0	2.00	938.0	2.80	2.96
		10.00		9-3240-2	26.0	520.0	2.00	650.0	2.50	910.0	3.50	3.70
		12.00		9-3248-2	21.9	525.6	2.40	657.0	3.00	919.8	4.20	4.44

* NOTE: For design purposes only. We do not recommend deflecting a spring to maximum deflection.

HEAVY DUTY DIE SPRINGS

COLOR CODED GOLD STRIPE

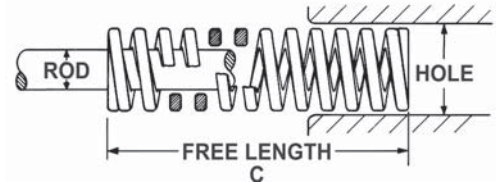
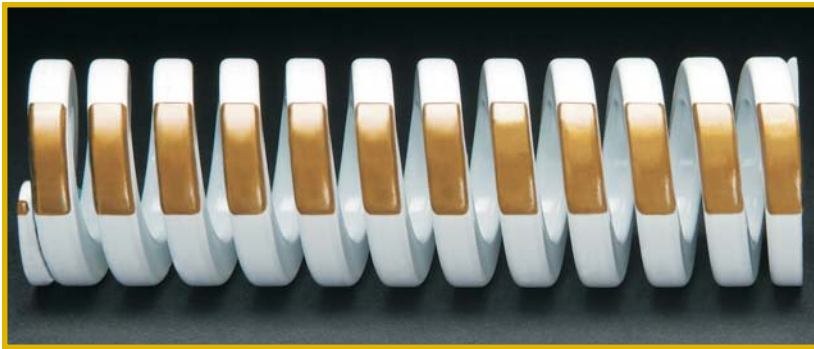

Hole Diam. (in)	Rod Diam. (in)	Free Length (in)	Wire Size (in)	CATALOG NUMBER	Pounds @ 1/10 inch defl.	Total Deflection Recommended for Long Life (15% of C)		Total Deflection Recommended for Avg. Life (20% of C)		Maximum Operating Deflection (28% of C)		Max. Defl. (30%)* (in)
						Load lbs.	Defl. in.	Load lbs.	Defl. in.	Load lbs.	Defl. in.	
3/8	3/16	1.00	0.053 X 0.071	9-0604-3	11.6	17.4	0.15	23.2	0.20	32.5	0.28	0.30
		1.25		9-0605-3	9.8	18.4	0.19	24.5	0.25	34.3	0.35	0.38
		1.50		9-0606-3	8.3	18.7	0.23	24.9	0.30	34.9	0.42	0.45
		1.75		9-0607-3	8.2	21.5	0.26	28.7	0.35	40.2	0.49	0.53
		2.00		9-0608-3	7.1	21.3	0.30	28.4	0.40	39.8	0.56	0.60
		2.50		9-0610-3	5.5	20.6	0.38	27.5	0.50	38.5	0.70	0.75
		3.00		9-0612-3	4.2	18.9	0.45	25.2	0.60	35.3	0.84	0.90
		12.00		9-0648-3	1.1	20.5	1.80	27.4	2.40	38.3	3.36	3.60
1/2	9/32	1.00	0.071 X 0.095	9-0804-3	23.6	35.4	0.15	47.2	0.20	66.1	0.28	0.30
		1.25		9-0805-3	18.6	34.9	0.19	46.5	0.25	65.1	0.35	0.38
		1.50		9-0806-3	15.5	34.9	0.23	46.5	0.30	65.1	0.42	0.45
		1.75		9-0807-3	13.8	36.2	0.26	48.3	0.35	67.6	0.49	0.53
		2.00		9-0808-3	11.0	33.0	0.30	44.0	0.40	61.6	0.56	0.60
		2.50		9-0810-3	8.4	31.5	0.38	42.0	0.50	58.8	0.70	0.75
		3.00		9-0812-3	7.4	33.3	0.45	44.4	0.60	62.2	0.84	0.90
		3.50		9-0814-3	6.0	31.5	0.53	42.0	0.70	58.8	0.98	1.05
12.00	9-0848-3	1.6	28.8	1.80	38.4	2.40	53.8	3.36	3.60			
5/8	11/32	1.00	0.096 X 0.115	9-1004-3	43.0	64.5	0.15	86.0	0.20	120.4	0.28	0.30
		1.25		9-1005-3	32.0	60.0	0.19	80.0	0.25	112.0	0.35	0.38
		1.50		9-1006-3	27.7	62.3	0.23	83.1	0.30	116.3	0.42	0.45
		1.75		9-1007-3	24.0	63.0	0.26	84.0	0.35	117.6	0.49	0.53
		2.00		9-1008-3	20.8	62.4	0.30	83.2	0.40	116.5	0.56	0.60
		2.50		9-1010-3	16.6	62.3	0.38	83.0	0.50	116.2	0.70	0.75
		3.00		9-1012-3	14.0	63.0	0.45	84.0	0.60	117.6	0.84	0.90
		3.50		9-1014-3	11.9	62.5	0.53	83.3	0.70	116.6	0.98	1.05
4.00	9-1016-3	10.4	62.4	0.60	83.2	0.80	116.5	1.12	1.20			
12.00	9-1048-3	3.1	55.8	1.80	74.4	2.40	104.2	3.36	3.60			
3/4	3/8	1.00	0.130 X 0.155	9-1204-3	108.8	163.2	0.15	217.6	0.20	304.6	0.28	0.30
		1.25		9-1205-3	88.0	165.0	0.19	220.0	0.25	308.0	0.35	0.38
		1.50		9-1206-3	68.4	153.9	0.23	205.2	0.30	287.3	0.42	0.45
		1.75		9-1207-3	60.0	157.5	0.26	210.0	0.35	294.0	0.49	0.53
		2.00		9-1208-3	49.8	149.4	0.30	199.2	0.40	278.9	0.56	0.60
		2.50		9-1210-3	40.0	150.0	0.38	200.0	0.50	280.0	0.70	0.75
		3.00		9-1212-3	34.0	153.0	0.45	204.0	0.60	285.6	0.84	0.90
		3.50		9-1214-3	28.0	147.0	0.53	196.0	0.70	274.4	0.98	1.05
		4.00		9-1216-3	25.0	150.0	0.60	200.0	0.80	280.0	1.12	1.20
		4.50		9-1218-3	22.0	148.5	0.68	198.0	0.90	277.2	1.26	1.35
		5.00		9-1220-3	19.5	146.3	0.75	195.0	1.00	273.0	1.40	1.50
		5.50		9-1222-3	17.0	140.3	0.83	187.0	1.10	261.8	1.54	1.65
6.00	9-1224-3	16.0	144.0	0.90	192.0	1.20	268.8	1.68	1.80			
12.00	9-1248-3	8.0	144.0	1.80	192.0	2.40	268.8	3.36	3.60			

* NOTE: For design purposes only. We do not recommend deflecting a spring to maximum deflection.

INCH STANDARD

COLOR CODED GOLD STRIPE

Hole Diam. (in)	Rod Diam. (in)	Free Length (in)	Wire Size (in)	CATALOG NUMBER	Pounds @ 1/10 inch defl.	Total Deflection Recommended for Long Life (15% of C)		Total Deflection Recommended for Avg. Life (20% of C)		Maximum Operating Deflection (28% of C)		Max. Defl. (30%)* (in)
						Load lbs.	Defl. in.	Load lbs.	Defl. in.	Load lbs.	Defl. in.	
1	1/2	1.00	0.165 X 0.216	9-1604-3	208.0	312.0	0.15	416.0	0.20	582.4	0.28	0.30
		1.25		9-1605-3	170.0	318.8	0.19	425.0	0.25	595.0	0.35	0.38
		1.50		9-1606-3	119.8	269.6	0.23	359.4	0.30	503.2	0.42	0.45
		1.75		9-1607-3	104.0	273.0	0.26	364.0	0.35	509.6	0.49	0.53
		2.00		9-1608-3	90.0	270.0	0.30	360.0	0.40	504.0	0.56	0.60
		2.50		9-1610-3	68.0	255.0	0.38	340.0	0.50	476.0	0.70	0.75
		3.00		9-1612-3	54.4	244.8	0.45	326.4	0.60	457.0	0.84	0.90
		3.50		9-1614-3	45.9	241.0	0.53	321.3	0.70	449.8	0.98	1.05
		4.00		9-1616-3	40.0	240.0	0.60	320.0	0.80	448.0	1.12	1.20
		4.50		9-1618-3	35.2	237.6	0.68	316.8	0.90	443.5	1.26	1.35
		5.00		9-1620-3	31.5	236.3	0.75	315.0	1.00	441.0	1.40	1.50
		5.50		9-1622-3	28.8	237.6	0.83	316.8	1.10	443.5	1.54	1.65
		6.00		9-1624-3	25.9	233.1	0.90	310.8	1.20	435.1	1.68	1.80
		7.00		9-1628-3	22.4	235.2	1.05	313.6	1.40	439.0	1.96	2.10
8.00	9-1632-3	19.2	230.4	1.20	307.2	1.60	430.1	2.24	2.40			
12.00	9-1648-3	12.5	225.0	1.80	300.0	2.40	420.0	3.36	3.60			
1 1/4	5/8	1.50	0.209 X 0.275	9-2006-3	212.0	477.0	0.23	636.0	0.30	890.4	0.42	0.45
		1.75		9-2007-3	181.0	475.1	0.26	633.5	0.35	886.9	0.49	0.53
		2.00		9-2008-3	149.6	448.8	0.30	598.4	0.40	837.8	0.56	0.60
		2.50		9-2010-3	117.2	439.5	0.38	586.0	0.50	820.4	0.70	0.75
		3.00		9-2012-3	95.0	427.5	0.45	570.0	0.60	798.0	0.84	0.90
		3.50		9-2014-3	77.0	404.3	0.53	539.0	0.70	754.6	0.98	1.05
		4.00		9-2016-3	66.4	398.4	0.60	531.2	0.80	743.7	1.12	1.20
		4.50		9-2018-3	58.4	394.2	0.68	525.6	0.90	735.8	1.26	1.35
		5.00		9-2020-3	53.0	397.5	0.75	530.0	1.00	742.0	1.40	1.50
		5.50		9-2022-3	47.2	389.4	0.83	519.2	1.10	726.9	1.54	1.65
		6.00		9-2024-3	42.9	386.1	0.90	514.8	1.20	720.7	1.68	1.80
		7.00		9-2028-3	36.8	386.4	1.05	515.2	1.40	721.3	1.96	2.10
		8.00		9-2032-3	32.8	393.6	1.20	524.8	1.60	734.7	2.24	2.40
		10.00		9-2040-3	25.6	384.0	1.50	512.0	2.00	716.8	2.80	3.00
12.00	9-2048-3	20.8	374.4	1.80	499.2	2.40	698.9	3.36	3.60			
1 1/2	3/4	2.00	0.245 X 0.328	9-2408-3	195.4	586.2	0.30	781.6	0.40	1094.2	0.56	0.60
		2.50		9-2410-3	155.0	581.3	0.38	775.0	0.50	1085.0	0.70	0.75
		3.00		9-2412-3	128.0	576.0	0.45	768.0	0.60	1075.2	0.84	0.90
		3.50		9-2414-3	106.4	558.6	0.53	744.8	0.70	1042.7	0.98	1.05
		4.00		9-2416-3	91.2	547.2	0.60	729.6	0.80	1021.4	1.12	1.20
		4.50		9-2418-3	78.4	529.2	0.68	705.6	0.90	987.8	1.26	1.35
		5.00		9-2420-3	71.2	534.0	0.75	712.0	1.00	996.8	1.40	1.50
		5.50		9-2422-3	64.0	528.0	0.83	704.0	1.10	985.6	1.54	1.65
		6.00		9-2424-3	58.4	525.6	0.90	700.8	1.20	981.1	1.68	1.80
		7.00		9-2428-3	49.6	520.8	1.05	694.4	1.40	972.2	1.96	2.10
		8.00		9-2432-3	43.2	518.4	1.20	691.2	1.60	967.7	2.24	2.40
		10.00		9-2440-3	34.4	516.0	1.50	688.0	2.00	963.2	2.80	3.00
		12.00		9-2448-3	28.8	518.4	1.80	691.2	2.40	967.7	3.36	3.60
		2		1	2.50	.305 X 0.450	9-3210-3	253.0	948.8	0.38	1265.0	0.50
3.00	9-3212-3		200.0		900.0		0.45	1200.0	0.60	1680.0	0.84	0.90
3.50	9-3214-3		170.0		892.5		0.53	1190.0	0.70	1666.0	0.98	1.05
4.00	9-3216-3		146.0		876.0		0.60	1168.0	0.80	1635.2	1.12	1.20
4.50	9-3218-3		120.0		810.0		0.68	1080.0	0.90	1512.0	1.26	1.35
5.00	9-3220-3		110.0		825.0		0.75	1100.0	1.00	1540.0	1.40	1.50
5.50	9-3222-3		100.0		825.0		0.83	1100.0	1.10	1540.0	1.54	1.65
6.00	9-3224-3		93.0		837.0		0.90	1116.0	1.20	1562.4	1.68	1.80
7.00	9-3228-3		79.0		829.5		1.05	1106.0	1.40	1548.4	1.96	2.10
8.00	9-3232-3		69.0		828.0		1.20	1104.0	1.60	1545.6	2.24	2.40
10.00	9-3240-3		54.4		816.0		1.50	1088.0	2.00	1523.2	2.80	3.00
12.00	9-3248-3		42.0		756.0		1.80	1008.0	2.40	1411.2	3.36	3.60

* NOTE: For design purposes only. We do not recommend deflecting a spring to maximum deflection.

EXTRA HEAVY DUTY DIE SPRINGS

COLOR CODED GREEN STRIPE

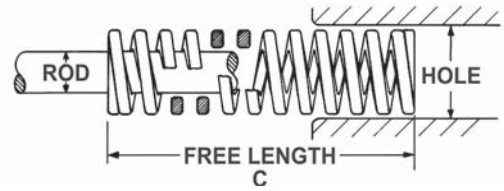
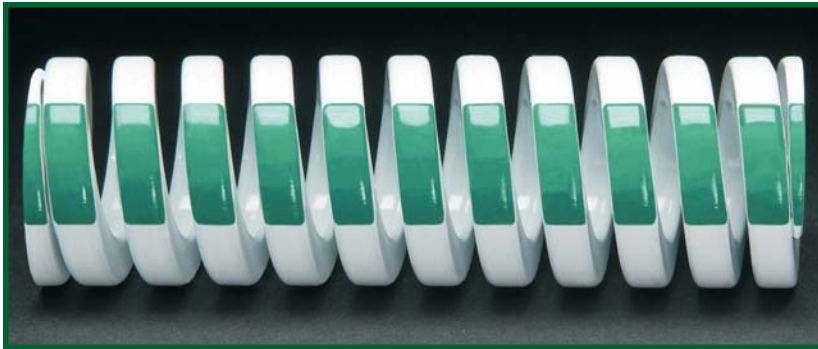

Hole Diam. (in)	Rod Diam. (in)	Free Length (in)	Wire Size (in)	CATALOG NUMBER	Pounds @ 1/10 inch defl.	Total Deflection Recommended for Long Life (15% of C)		Total Deflection Recommended for Avg. Life (17% of C)		Maximum Operating Deflection (25% of C)		Max. Defl. (28%)* (in)
						Load lbs.	Defl. in.	Load lbs.	Defl. in.	Load lbs.	Defl. in.	
3/8	3/16	1.00	0.063 X 0.073	9-0604-4	20.5	30.8	0.15	34.9	0.17	51.3	0.25	0.28
		1.25		9-0605-4	16.0	30.0	0.19	34.0	0.21	50.0	0.31	0.35
		1.50		9-0606-4	12.5	28.1	0.23	31.9	0.26	46.9	0.38	0.42
		1.75		9-0607-4	11.1	29.1	0.26	33.0	0.30	48.6	0.44	0.49
		2.00		9-0608-4	9.0	27.0	0.30	30.6	0.34	45.0	0.50	0.56
		2.50		9-0610-4	7.0	26.3	0.38	29.8	0.43	43.8	0.63	0.70
		3.00		9-0612-4	6.3	28.4	0.45	32.1	0.51	47.3	0.75	0.84
		12.00		9-0648-4	1.5	27.0	1.80	30.6	2.04	45.0	3.00	3.36
1/2	9/32	1.00	0.088 X 0.090	9-0804-4	32.0	48.0	0.15	54.4	0.17	80.0	0.25	0.28
		1.25		9-0805-4	24.2	45.4	0.19	51.4	0.21	75.6	0.31	0.35
		1.50		9-0806-4	20.0	45.0	0.23	51.0	0.26	75.0	0.38	0.42
		1.75		9-0807-4	17.0	44.6	0.26	50.6	0.30	74.4	0.44	0.49
		2.00		9-0808-4	14.5	43.5	0.30	49.3	0.34	72.5	0.50	0.56
		2.50		9-0810-4	11.5	43.1	0.38	48.9	0.43	71.9	0.63	0.70
		3.00		9-0812-4	9.4	42.3	0.45	47.9	0.51	70.5	0.75	0.84
		3.50		9-0814-4	8.0	42.0	0.53	47.6	0.60	70.0	0.88	0.98
12.00	9-0848-4	2.5	45.0	1.80	51.0	2.04	75.0	3.00	3.36			
5/8	11/32	1.00	0.115 X 0.120	9-1004-4	63.0	94.5	0.15	107.1	0.17	157.5	0.25	0.28
		1.25		9-1005-4	47.0	88.1	0.19	99.9	0.21	146.9	0.31	0.35
		1.50		9-1006-4	38.0	85.5	0.23	96.9	0.26	142.5	0.38	0.42
		1.75		9-1007-4	32.0	84.0	0.26	95.2	0.30	140.0	0.44	0.49
		2.00		9-1008-4	29.0	87.0	0.30	98.6	0.34	145.0	0.50	0.56
		2.50		9-1010-4	22.0	82.5	0.38	93.5	0.43	137.5	0.63	0.70
		3.00		9-1012-4	19.0	85.5	0.45	96.9	0.51	142.5	0.75	0.84
		3.50		9-1014-4	16.0	84.0	0.53	95.2	0.60	140.0	0.88	0.98
4.00	9-1016-4	13.5	81.0	0.60	91.8	0.68	135.0	1.00	1.12			
12.00	9-1048-4	4.5	81.0	1.80	91.8	2.04	135.0	3.00	3.36			
3/4	3/8	1.00	0.140 X 0.155	9-1204-4	140.0	210.0	0.15	238.0	0.17	350.0	0.25	0.28
		1.25		9-1205-4	110.0	206.3	0.19	233.8	0.21	343.8	0.31	0.35
		1.50		9-1206-4	89.0	200.3	0.23	227.0	0.26	333.8	0.38	0.42
		1.75		9-1207-4	75.0	196.9	0.26	223.1	0.30	328.1	0.44	0.49
		2.00		9-1208-4	68.0	204.0	0.30	231.2	0.34	340.0	0.50	0.56
		2.50		9-1210-4	50.0	187.5	0.38	212.5	0.43	312.5	0.63	0.70
		3.00		9-1212-4	40.5	182.3	0.45	206.6	0.51	303.8	0.75	0.84
		3.50		9-1214-4	34.5	181.1	0.53	205.3	0.60	301.9	0.88	0.98
		4.00		9-1216-4	30.0	180.0	0.60	204.0	0.68	300.0	1.00	1.12
		4.50		9-1218-4	26.5	178.9	0.68	202.7	0.77	298.1	1.13	1.26
		5.00		9-1220-4	23.5	176.3	0.75	199.8	0.85	293.8	1.25	1.40
		5.50		9-1222-4	21.5	177.4	0.83	201.0	0.94	295.6	1.38	1.54
6.00	9-1224-4	19.5	175.5	0.90	198.9	1.02	292.5	1.50	1.68			
12.00	9-1248-4	9.5	171.0	1.80	193.8	2.04	285.0	3.00	3.36			

* NOTE: For design purposes only. We do not recommend deflecting a spring to maximum deflection.

INCH STANDARD

COLOR CODED GREEN STRIPE

Hole Diam. (in)	Rod Diam. (in)	Free Length (in)	Wire Size (in)	CATALOG NUMBER	Pounds @ 1/10 inch defl.	Total Deflection Recommended for Long Life (15% of C)		Total Deflection Recommended for Avg. Life (17% of C)		Maximum Operating Deflection (25% of C)		Max. Defl. (28%)* (in)
						Load lbs.	Defl. in.	Load lbs.	Defl. in.	Load lbs.	Defl. in.	
1	1/2	1.50	0.182 X 0.215	9-1606-4	160.0	360.0	0.23	408.0	0.26	600.0	0.38	0.42
		2.00		9-1608-4	116.0	348.0	0.30	394.4	0.34	580.0	0.50	0.56
		2.50		9-1610-4	89.6	336.0	0.38	380.8	0.43	560.0	0.63	0.70
		3.00		9-1612-4	73.6	331.2	0.45	375.4	0.51	552.0	0.75	0.84
		3.50		9-1614-4	62.4	327.6	0.53	371.3	0.60	546.0	0.88	0.98
		4.00		9-1616-4	55.2	331.2	0.60	375.4	0.68	552.0	1.00	1.12
		4.50		9-1618-4	48.8	329.4	0.68	373.3	0.77	549.0	1.13	1.26
		5.00		9-1620-4	43.2	324.0	0.75	367.2	0.85	540.0	1.25	1.40
		6.00		9-1624-4	36.0	324.0	0.90	367.2	1.02	540.0	1.50	1.68
12.00	9-1648-4	17.6	316.8	1.80	359.0	2.04	528.0	3.00	3.36			
1 1/4	5/8	2.00	0.226 X 0.280	9-2008-4	192.0	576.0	0.30	652.8	0.34	960.0	0.50	0.56
		2.50		9-2010-4	146.2	548.3	0.38	621.4	0.43	913.8	0.63	0.70
		3.00		9-2012-4	118.4	532.8	0.45	603.8	0.51	888.0	0.75	0.84
		3.50		9-2014-4	100.8	529.2	0.53	599.8	0.60	882.0	0.88	0.98
		4.00		9-2016-4	85.0	510.0	0.60	578.0	0.68	850.0	1.00	1.12
		4.50		9-2018-4	78.4	529.2	0.68	599.8	0.77	882.0	1.13	1.26
		5.00		9-2020-4	68.0	510.0	0.75	578.0	0.85	850.0	1.25	1.40
		6.00		9-2024-4	56.0	504.0	0.90	571.2	1.02	840.0	1.50	1.68
		8.00		9-2032-4	41.6	499.2	1.20	565.8	1.36	832.0	2.00	2.24
10.00	9-2040-4	33.6	504.0	1.50	571.2	1.70	840.0	2.50	2.80			
12.00	9-2048-4	26.4	475.2	1.80	538.6	2.04	792.0	3.00	3.36			
1 1/2	3/4	2.00	0.290 X 0.330	9-2408-4	370.0	1110.0	0.30	1258.0	0.34	1850.0	0.50	0.56
		2.50		9-2410-4	285.0	1068.8	0.38	1211.3	0.43	1781.3	0.63	0.70
		3.00		9-2412-4	231.2	1040.4	0.45	1179.1	0.51	1734.0	0.75	0.84
		3.50		9-2414-4	196.0	1029.0	0.53	1166.2	0.60	1715.0	0.88	0.98
		4.00		9-2416-4	171.0	1026.0	0.60	1162.8	0.68	1710.0	1.00	1.12
		4.50		9-2418-4	148.0	999.0	0.68	1132.2	0.77	1665.0	1.13	1.26
		5.00		9-2420-4	135.0	1012.5	0.75	1147.5	0.85	1687.5	1.25	1.40
		6.00		9-2424-4	110.4	993.6	0.90	1126.1	1.02	1656.0	1.50	1.68
		8.00		9-2432-4	80.8	969.6	1.20	1098.9	1.36	1616.0	2.00	2.24
10.00	9-2440-4	65.0	975.0	1.50	1105.0	1.70	1625.0	2.50	2.80			
12.00	9-2448-4	54.0	972.0	1.80	1101.6	2.04	1620.0	3.00	3.36			
2	1	2.50	0.350 X 0.452	9-3210-4	387.0	1451.3	0.38	1644.8	0.43	2418.8	0.63	0.70
		3.00		9-3212-4	312.0	1404.0	0.45	1591.2	0.51	2340.0	0.75	0.84
		3.50		9-3214-4	254.4	1335.6	0.53	1513.7	0.60	2226.0	0.88	0.98
		4.00		9-3216-4	220.0	1320.0	0.60	1496.0	0.68	2200.0	1.00	1.12
		4.50		9-3218-4	189.7	1280.5	0.68	1451.2	0.77	2134.1	1.13	1.26
		5.00		9-3220-4	172.8	1296.0	0.75	1468.8	0.85	2160.0	1.25	1.40
		6.00		9-3224-4	141.6	1274.4	0.90	1444.3	1.02	2124.0	1.50	1.68
		8.00		9-3232-4	101.5	1218.0	1.20	1380.4	1.36	2030.0	2.00	2.24
		10.00		9-3240-4	84.0	1260.0	1.50	1428.0	1.70	2100.0	2.50	2.80
12.00	9-3248-4	70.0	1260.0	1.80	1428.0	2.04	2100.0	3.00	3.36			

* NOTE: For design purposes only. We do not recommend deflecting a spring to maximum deflection.

SPRING ACCESSORIES

SPRING CAGES

- ◆ Our spring cages enhance die spring life by providing a flat, hardened die pocket for spring operation.
- ◆ Material: A513 tube steel
- ◆ Conforms to NAAMS standards.

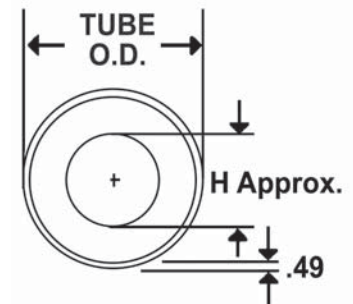
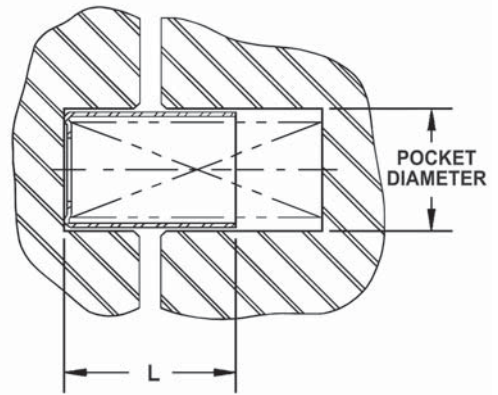

Spring Diameter (in)	Pocket Diameter (in)	Tube O.D. (in)	Diameter (H) (in)
3/4	29/32	0.855	7/16
1	1 5/32	1.105	9/16
1 1/4	1 13/32	1.355	3/4
1 1/2	1 21/32	1.605	31/32
2	2 5/32	2.105	1 3/8

Length L (in)	3/4 inch Diameter Springs		1 inch Diameter Springs		1 1/4 inch Diameter Springs		1 1/2 inch Diameter Springs		2 inch Diameter Springs	
	CATALOG NUMBER	NAAMS Code	CATALOG NUMBER	NAAMS Code	CATALOG NUMBER	NAAMS Code	CATALOG NUMBER	NAAMS Code	CATALOG NUMBER	NAAMS Code
1	6-8	S212025	8-8	S212525	10-8	S213225	12-8	S214025	16-8	S215025
1 1/4	6-10	S212032	8-10	S212532	10-10	S213232	12-10	S214032	16-10	S215032
1 1/2	6-12	S212038	8-12	S212538	10-12	S213238	12-12	S214038	16-12	S215038
1 3/4	6-14	S212044	8-14	S212544	10-14	S213244	12-14	S214044	16-14	S215044
2	6-16	S212051	8-16	S212551	10-16	S213251	12-16	S214051	16-16	S215051
2 1/4	6-18	-	8-18	-	10-18	-	12-18	-	16-18	-
2 1/2	6-20	S212064	8-20	S212564	10-20	S213264	12-20	S214064	16-20	S215064
2 3/4	6-22	-	8-22	-	10-22	-	12-22	-	16-22	-
3	6-24	S212076	8-24	S212576	10-24	S213276	12-24	S214076	16-24	S215076
3 1/4	6-26	-	8-26	-	10-26	-	12-26	-	16-26	-
3 1/2	6-28	S212089	8-28	S212589	10-28	S213289	12-28	S214089	16-28	S215089
3 3/4	6-30	-	8-30	-	10-30	-	12-30	-	16-30	-
4	6-32	S212010	8-32	S212510	10-32	S213210	12-32	S214010	16-32	S215010
4 1/4	6-34	-	8-34	-	10-34	-	12-34	-	16-34	-
4 1/2	6-36	-	8-36	-	10-36	-	12-36	-	16-36	-
4 3/4	6-38	-	8-38	-	10-38	-	12-38	-	16-38	-
5	6-40	S212012	8-40	S212512	10-40	S213212	12-40	S214012	16-40	S215012
5 1/2	6-44	-	8-44	-	10-44	-	12-44	-	16-44	-
6	6-48	S212015	8-48	S212515	10-48	S213215	12-48	S214015	16-48	S215015
6 1/2	6-52	-	8-52	-	10-52	-	12-52	-	16-52	-
7	6-56	S212017	8-56	S212517	10-56	S213217	12-56	S214017	16-56	S215017
8	6-64	S212020	8-64	S212520	10-64	S213220	12-64	S214020	16-64	S215020
9	-	-	-	-	10-72	S213222	12-72	S214022	16-72	S215022
10	-	-	-	-	10-80	-	12-80	-	16-80	-
11	-	-	-	-	-	-	-	-	16-88	S215028
12	-	-	-	-	-	-	-	-	16-96	S215030

SPRING ACCESSORIES

SPRING RETAINERS



- ◆ Our spring retainers hold individual springs firmly in position while the die is being assembled or disassembled. Pre-loading the spring is easy since the springs can be set individually, which avoids working against the combined force of the springs.
- ◆ Available for springs 1 1/4", 1 1/2" and 2" diameters and any free length where clearance permits.
- ◆ Material: steel

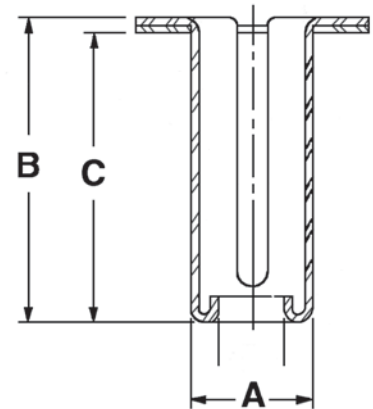
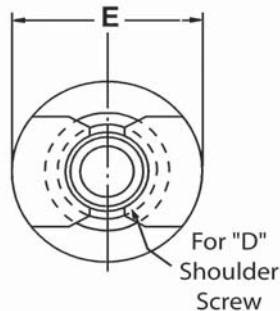
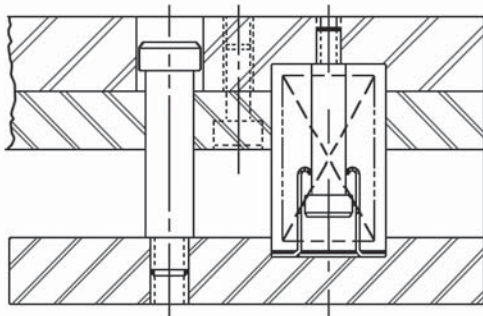

CATALOG NUMBER	Spring Diameter (in)	Rod Diameter A (in)	B (in)	C (in)	Shoulder Screw D (in)	E (in)
SR125150	1 1/4	5/8	1 11/16	1 1/2	5/16	1 1/4
SR125200			2 3/16	2		1 1/4
SR125250			2 11/16	2 1/2		1 1/4
SR150150	1 1/2	3/4	1 11/16	1 1/2	3/8	1 1/2
9-0615-16			1 7/8	1 3/4		1 7/16
SR150200			2 3/16	2		1 1/2
SR150250			2 11/16	2 1/2		1 1/2
SR200150	2	1	1 11/16	1 1/2	1/2	2
9-0815-16			1 3/4	1 3/4		1 5/16
SR200200			2 3/16	2		2
SR200250			2 11/16	2 1/2		2
9-0823-16			2 7/8	2 3/4		1 5/16

ALL-STEEL DIE SETS

LARGE TWO POST STYLES

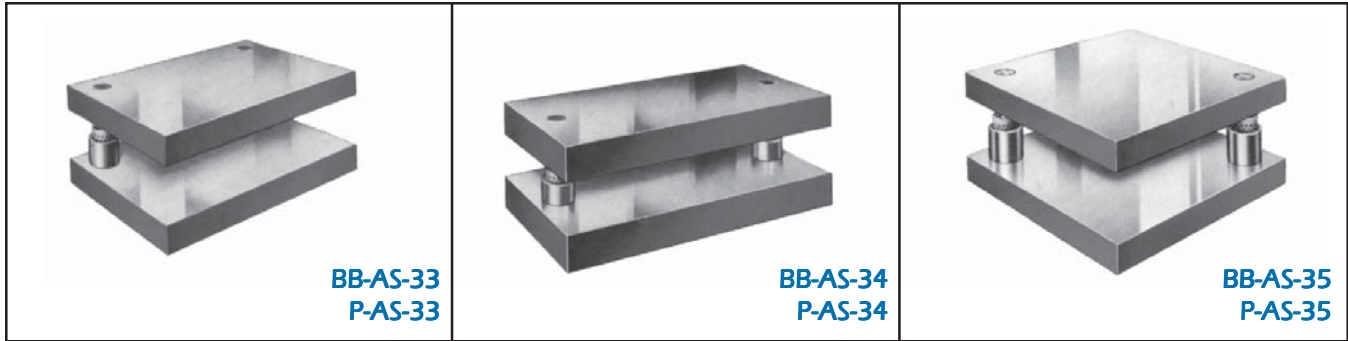

SUGGESTED MINIMUM DIMENSIONS

WHEN	A = 6 to 11"				A = 12 to 17"				A = 18 to 23"				A = 24 to 29"			
B=	J	K	O	P	J	K	O	P	J	K	O	P	J	K	O	P
6 to 8"	1 1/2	1 1/2	1 1/4	1	1 1/2	1 1/2	1 1/4	1	1 1/2	1 1/2	1 1/2	1 1/4	1 1/2	1 1/2	1 1/2	1 1/4
9 to 11"	1 1/2	1 1/2	1 1/2	1 1/4	1 1/2	1 1/2	1 1/2	1 1/4	1 3/4	1 3/4	1 3/4	1 1/2	1 3/4	1 3/4	1 3/4	1 1/2
12 to 17"	-	-	1 1/2	1 1/4	1 3/4	1 3/4	1 3/4	1 1/2	2	2	2	1 3/4	2	2	2	1 3/4
18 to 23"	-	-	1 3/4	1 1/2	-	-	1 3/4	1 1/2	2	2	2	1 3/4	2 1/2	2 1/2	2 1/2	2
24 to 29"	-	-	2	1 3/4	-	-	2	1 3/4	-	-	2 1/2	2	2 1/2	2 1/2	2 1/2	2
30 to 44"	-	-	2 1/2	2	-	-	2 1/2	2	-	-	2 1/2	2	-	-	3	2 1/2
45 to 60"	-	-	3	2 1/2	-	-	3	2 1/2	-	-	3	2 1/2	-	-	3	2 1/2

WHEN	A = 30 TO 44"				A = 45 TO 69"				A = 70 TO 100"			
B=	J	K	O	P	J	K	O	P	J	K	O	P
6 to 8"	1 3/4	1 3/4	1 3/4	1 1/2	2	2	2	1 3/4	2	2	2	1 3/4
9 to 11"	2	2	2	1 3/4	2	2	2	1 3/4	2	2	2	1 3/4
12 to 17"	2 1/2	2 1/2	2 1/2	2	2 1/2	2 1/2	2 1/2	2	2 1/2	2 1/2	2 1/2	2
18 to 23"	2 1/2	2 1/2	2 1/2	2	2 1/2	2 1/2	2 1/2	2	2 1/2	2 1/2	2 1/2	2
24 to 29"	2 1/2	2 1/2	2 1/2	2	3	3	3	2 1/2	3	3	3	2 1/2
30 to 44"	3	3	2 1/2	2	3	3	3	2 1/2	3	3	3	2 1/2
45 to 60"	-	-	3	2 1/2	3	3	3	2 1/2	3 1/2	3 1/2	3	2 1/2

NOMINAL DIMENSIONS

NOMINAL GUIDE POST DIAMETER	BALL BEARING								PLAIN BEARING							
	Sleeve Bushing				Shoulder Bushing				Sleeve Bushing				Shoulder Bushing			
	C	F	V	FF	C	F	V	FF	C	F	V	FF	C	F	V	FF
1	1 1/2	2	3/8	2 3/8	1 1/2	2	1/2	2 1/2	1 1/2	2	1/4	2 1/4	1 1/2	2	3/8	2 3/8
1 1/4	1 3/4	2 3/8	1/2	2 7/8	1 3/4	2 3/8	5/8	3	1 3/4	2 3/8	1/4	2 5/8	1 3/4	2 3/8	3/8	2 3/4
1 1/2	2	2 3/4	1/2	3 1/4	2	2 3/4	5/8	3 3/8	2	2 3/4	1/4	3	2	2 3/4	3/8	3 1/8
1 3/4	2 1/8	3	1/2	3 1/2	2 1/8	3	5/8	3 5/8	2 1/8	3	1/4	3 1/4	2 1/8	3	3/8	3 3/8
2	2 3/8	3 3/8	5/8	4	2 3/8	3 3/8	7/8	4 1/4	2 3/8	3 3/8	1/4	3 5/8	2 3/8	3 3/8	3/8	3 3/4
2 1/2	2 5/8	3 7/8	5/8	4 1/2	2 5/8	3 7/8	7/8	4 3/4	2 5/8	3 7/8	3/8	4 1/4	2 5/8	3 7/8	5/8	4 1/2
3	3	4 1/2	5/8	5 1/8	3	4 1/2	7/8	5 3/8	3	4 1/2	3/8	4 7/8	3	4 1/2	5/8	5 1/8

FORMULAS		PLATE THICKNESSES STOCKED FOR IMMEDIATE FABRICATION				
AA = A - 2V	S = A + 2F T = B + F X = B - 2F	1	1 1/8	1 1/4	1 3/8	1 1/2
BB = B - V		1 5/8	1 3/4	1 7/8	2	2 1/4
Y = A - 2FF		2 1/2	2 3/4	3	3 1/4	3 1/2
XX = B - 2FF		4	4 1/2	5	5 1/2	6
		6 1/2	7			

ALL-STEEL DIE SETS

LARGE TWO POST STYLES

BOLT CIRCLE DIAMETERS	
DEMOUNTABLE BALL BEARING BUSHINGS	
NOMINAL BUSHING DIAMETER	BOLT CIRCLE DIAMETER
1	2.438
1 1/4	2.813
1 1/2	3.125
1 3/4	3.438
2	4.000
2 1/2	4.500
3	5.000
DEMOUNTABLE BALL BEARING PINS	
NOMINAL BUSHING DIAMETER	BOLT CIRCLE DIAMETER
1	1.750
1 1/4	2.000
1 1/2	2.250
1 3/4	2.625
2	2.875
2 1/2	3.375
3	3.875

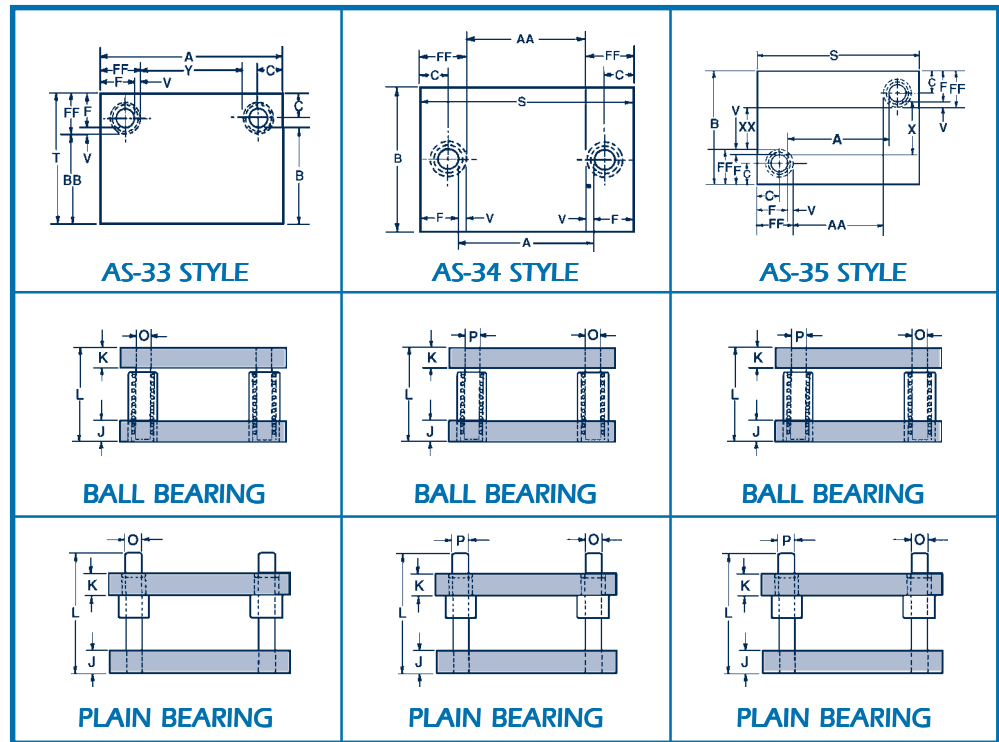

LEMPCO Large Two Post All-Steel Die Sets are offered in Ball Bearing and Plain Bearing designs, in Back Post, Center Post and Diagonal Post styles. Special machining, torch cutting and welded components are available to the details of your print.

WHEN ORDERING, SPECIFY:

1. Select either Ball Bearing or Plain Bearing in the specified series (EXAMPLE: BB-AS-33 or P-AS-33).
2. Specify clamp arrangement (L-R feed or F-B feed) from drawing shown at right.
3. Specify the dimensions "A" and "B".
4. Specify the thickness of the die holder "J" and the punch holder "K".
5. Specify the type of bushing. Unless otherwise specified, Ball Bearing Sets will be furnished with Press Fit Steel Sleeve Bushings, and Plain Bearing Sets will be stocked with Lamina Plain Bearing components.
6. Specify the length "L". For Ball Bearing sets, this is the Minimum Shut Height dimension. For Plain Bearing sets, this is the dimension from the bottom of the die holder to the top of the Guide Post.
7. Specify the diameter of the Guide Post if other than listed. Larger or smaller diameter guide posts than listed will cause dimensional variations.
8. Specify "no shank" or "Lempcoshank". Specify the shank diameter and length. If "Lempcoshank", give the catalog number of the kit desired. Specify the exact location of the shank relative to the guide post locations. All shanks are furnished at extra cost.
9. All shipments are via our designated carrier unless otherwise specified.

NOTE: All **LEMPCO** Plain Bearing die sets will be assembled with Lamina Plain Bearing components.

DEMOUNTABLE SHOULDER BUSHING CLAMP ARRANGEMENT SELECTION DATA			
NOM. POST DIA.	A (L-R FEED)	B (F-B FEED) (CENTER POST SETS)	C (ROUND DIES)
1, 1 1/4 & 1 1/2			
1 3/4, 2, 2 1/2 & 3			
1 3/4, 2, 2 1/2 & 3			
1 3/4, 2, 2 1/2 & 3			

LEMPCO will honor all existing Ball Bearing and Plain Bearing catalog die set part numbers (BT, LT, BF, LF, BB, P).

These die sets may not be returned for credit.

ALL-STEEL DIE SETS

LARGE FOUR POST STYLES

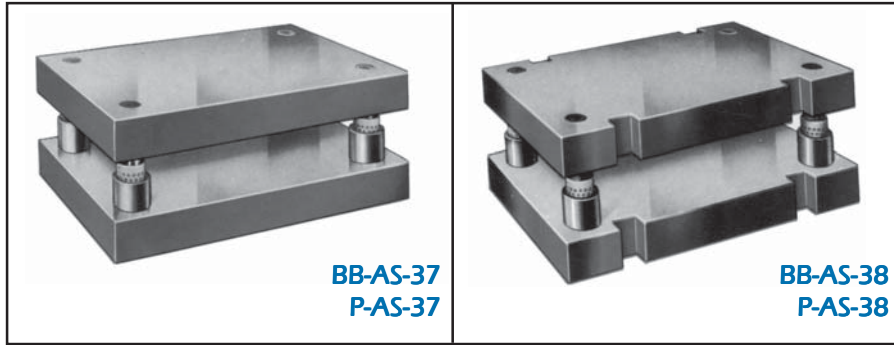

Sizes shown below are suggested minimums, but are not limited to these dimensions.

TO INSIDE OF POST	F	2	2 3/8	2 3/4	3	3 3/8	3 7/8																				
MINIMUM THICKNESS RECOMMENDED	K	1 1/4	1 1/4	1 1/2	1 3/4	2	2 1/2																				
	J	1 1/4	1 1/2	1 3/4	2	2 1/4	2 3/4																				
POST DIAMETER	O	1	1 1/4	1 1/2	1 3/4	2	2 1/2																				
DIE SPACE A →		6	8	10	12	14	16	18	20	22	24	26	28	30	32	34	36	40	45	50	55	60	65	70	80	90	100
B ↓	6	Shaded	Shaded	Shaded																							
	8	Shaded	Shaded	Shaded	Shaded	Shaded	Shaded	Shaded	Shaded	Shaded	Shaded	Shaded	Shaded	Shaded	Shaded	Shaded	Shaded	Shaded	Shaded	Shaded	Shaded	Shaded	Shaded	Shaded	Shaded	Shaded	Shaded
	10	Shaded	Shaded	Shaded	Shaded	Shaded	Shaded	Shaded	Shaded	Shaded	Shaded	Shaded	Shaded	Shaded	Shaded	Shaded	Shaded	Shaded	Shaded	Shaded	Shaded	Shaded	Shaded	Shaded	Shaded	Shaded	Shaded
	12			Shaded	Shaded	Shaded	Shaded	Shaded	Shaded	Shaded	Shaded	Shaded	Shaded	Shaded	Shaded	Shaded	Shaded	Shaded	Shaded	Shaded	Shaded	Shaded	Shaded	Shaded	Shaded	Shaded	Shaded
	14				Shaded	Shaded	Shaded	Shaded	Shaded	Shaded	Shaded	Shaded	Shaded	Shaded	Shaded	Shaded	Shaded	Shaded	Shaded	Shaded	Shaded	Shaded	Shaded	Shaded	Shaded	Shaded	Shaded
	16					Shaded	Shaded	Shaded	Shaded	Shaded	Shaded	Shaded	Shaded	Shaded	Shaded	Shaded	Shaded	Shaded	Shaded	Shaded	Shaded	Shaded	Shaded	Shaded	Shaded	Shaded	Shaded
	18						Shaded	Shaded	Shaded	Shaded	Shaded	Shaded	Shaded	Shaded	Shaded	Shaded	Shaded	Shaded	Shaded	Shaded	Shaded	Shaded	Shaded	Shaded	Shaded	Shaded	Shaded
	20							Shaded	Shaded	Shaded	Shaded	Shaded	Shaded	Shaded	Shaded	Shaded	Shaded	Shaded	Shaded	Shaded	Shaded	Shaded	Shaded	Shaded	Shaded	Shaded	Shaded
	22								Shaded	Shaded	Shaded	Shaded	Shaded	Shaded	Shaded	Shaded	Shaded	Shaded	Shaded	Shaded	Shaded	Shaded	Shaded	Shaded	Shaded	Shaded	Shaded
	24									Shaded	Shaded	Shaded	Shaded	Shaded	Shaded	Shaded	Shaded	Shaded	Shaded	Shaded	Shaded	Shaded	Shaded	Shaded	Shaded	Shaded	Shaded
	26										Shaded	Shaded	Shaded	Shaded	Shaded	Shaded	Shaded	Shaded	Shaded	Shaded	Shaded	Shaded	Shaded	Shaded	Shaded	Shaded	Shaded
	28											Shaded	Shaded	Shaded	Shaded	Shaded	Shaded	Shaded	Shaded	Shaded	Shaded	Shaded	Shaded	Shaded	Shaded	Shaded	Shaded
	30												Shaded	Shaded	Shaded	Shaded	Shaded	Shaded	Shaded	Shaded	Shaded	Shaded	Shaded	Shaded	Shaded	Shaded	Shaded
32													Shaded	Shaded	Shaded	Shaded	Shaded	Shaded	Shaded	Shaded	Shaded	Shaded	Shaded	Shaded	Shaded	Shaded	
34														Shaded	Shaded	Shaded	Shaded	Shaded	Shaded	Shaded	Shaded	Shaded	Shaded	Shaded	Shaded	Shaded	
36															Shaded	Shaded	Shaded	Shaded	Shaded	Shaded	Shaded	Shaded	Shaded	Shaded	Shaded	Shaded	
40																Shaded	Shaded	Shaded	Shaded	Shaded	Shaded	Shaded	Shaded	Shaded	Shaded	Shaded	
45																	Shaded	Shaded	Shaded	Shaded	Shaded	Shaded	Shaded	Shaded	Shaded	Shaded	
50																		Shaded	Shaded	Shaded	Shaded	Shaded	Shaded	Shaded	Shaded	Shaded	
55																			Shaded	Shaded	Shaded	Shaded	Shaded	Shaded	Shaded	Shaded	
60																				Shaded	Shaded	Shaded	Shaded	Shaded	Shaded	Shaded	

NOTE: Die space sizes are grouped within shaded areas which indicate suggested guide post diameters.

ALL-STEEL DIE SETS

LARGE FOUR POST STYLES

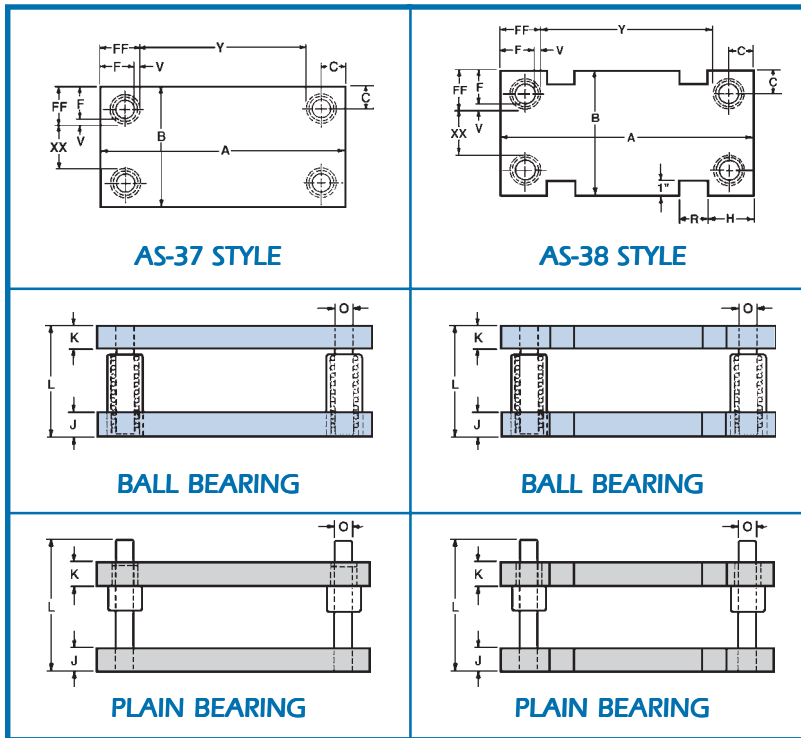

BOLT CIRCLE DIAMETERS			
DEMOUNTABLE BALL BEARING BUSHINGS		DEMOUNTABLE BALL BEARING PINS	
NOMINAL BUSHING DIAMETER	BOLT CIRCLE DIAMETER	NOMINAL BUSHING DIAMETER	BOLT CIRCLE DIAMETER
1	2.438	1	1.750
1 1/4	2.813	1 1/4	2.000
1 1/2	3.125	1 1/2	2.250
1 3/4	3.438	1 3/4	2.625
2	4.000	2	2.875
2 1/2	4.500	2 1/2	3.375
3	5.000	3	3.875

LEMPCO Large Four Post All-Steel Die Sets are available in Ball Bearing and Plain Bearing types, in two designs of the die and punch holders. Special machining, torch cutting and welded components are available to your print.

WHEN ORDERING, SPECIFY:

1. Select either Ball Bearing or Plain Bearing in the specified series (EXAMPLE: BB-AS-37 or P-AS-37).
2. Specify clamp arrangement (L-R feed or F-B feed) from drawing shown at right.
3. Specify the dimensions "A" and "B".
4. Specify the thickness of the die holder "J" and the punch holder "K".
5. Specify the type of bushing. Unless otherwise specified, Ball Bearing Sets will be furnished with Press Fit Steel Sleeve Bushings, and Plain Bearing Sets will be stocked with Lamina Plain Bearing components.
6. Specify the length "L". For Ball Bearing sets, this is the Minimum Shut Height dimension. For Plain Bearing sets, this is the dimension from the bottom of the die holder to the top of the Guide Post.
7. Specify the diameter of the Guide Post if other than listed. Larger or smaller diameter guide posts than listed will cause dimensional variations.
8. Specify "no shank" or "Lempcoshank". Specify the shank diameter and length. If "Lempcoshank", give the catalog number of the kit desired. Specify the exact location of the shank relative to the guide post locations. All shanks are furnished at extra cost.
9. All shipments are via our designated carrier unless otherwise specified.

NOTES:

1. When ordering a Lempco 4-Post Special Die Set, indicate on the Purchase Order and on the CAD file the pin offset you require or use the Lempco standard pin offset:
 - a. Left rear pin is offset to the **RIGHT**.
 - b. Die sets up to 48" left to right are offset .125" from pin location.
 - c. Die sets over 48" left to right are offset .250" from pin location.

2. All **LEMPCO** Plain Bearing die sets will be assembled with Lamina Plain Bearing components.

DEMOUNTABLE SHOULDER BUSHING CLAMP ARRANGEMENT SELECTION DATA			
NOM. POST DIA.	A (L-R FEED)	B (F-B FEED) (CENTER POST SETS)	C (ROUND DIES)
1, 1 1/4 & 1 1/2			
1 3/4, 2, 2 1/2 & 3			
1 3/4, 2, 2 1/2 & 3			
1 3/4, 2, 2 1/2 & 3			

LEMPCO will honor all existing Ball Bearing and Plain Bearing catalog die set part numbers (BT, LT, BF, LF, BB, P).

These die sets may not be returned for credit.

BALL & PLAIN BEARINGS DIE SETS

FLANGED TWO POST STYLES

- Easy to assemble
- Guidance accuracy for holding tight tolerances
- Less die wear, less scrap and less chance of seizures during operation
- Clamping flanges for security in the press

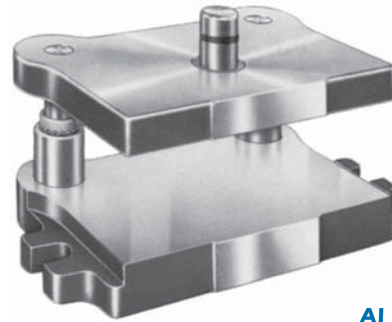

ALL STEEL

NOMINAL DIMENSIONS															
Left to Right A	Front to Back B (BB)	Die Holder J	Punch Holder K	C	D	E	F	G	M	N	O	R	S	T	Min. Shut Height L
4 reg.	4 (4 3/8)	1 3/8	1 1/4	4 7/8	3 1/4	2 7/16	1 1/2	5 1/2	6 1/4	3 15/16	1	6	7 1/2	6 3/8	5 1/4
4 rev.	5 (5 3/8)	1 3/8	1 1/4	5 7/8	4	2 11/16	1 1/2	6 1/2	7	4 3/16	1	6	7 3/4	7 3/8	5 1/4
5 reg.	4 (4 3/8)	1 3/8	1 1/4	4 7/8	4	2 3/16	1 1/2	5 1/2	7	3 11/16	1	6 3/4	8 1/4	6 3/8	5 1/4
5 reg.	5 (5 3/8)	1 1/2	1 1/4	5 7/8	4	2 11/16	1 1/2	6 1/2	7	4 3/16	1	6 3/4	8 1/4	7 3/8	5 1/4
6 1/2 reg.	4 (4 3/8)	1 1/2	1 1/4	4 7/8	5 1/8	2 1/8	1 1/2	5 1/2	8 1/8	3 5/8	1	8 5/8	10 1/2	6 3/8	5 1/4
		1 3/4	1 1/4												5 1/2
6 1/2 reg.	6 (6 3/8)	1 1/2	1 1/4	6 7/8	5 1/8	3 3/16	1 1/2	7 1/2	8 1/8	4 11/16	1	8 5/8	10 1/2	8 3/8	5 1/4
		1 1/2	1 3/4												5 3/4
		2	1 3/4												6
7 1/2 reg.	5 (5 3/8)	1 1/2	1 1/4	5 7/8	6 1/2	2 3/4	1 1/2	6 1/2	9 1/2	4 1/4	1	9 1/4	11	7 3/8	5 1/4
		1 1/2	1 3/4												5 3/4
		2	1 1/4												5 3/4
		2	1 3/4												6
7 1/2 reg.	7 (7 3/8)	1 1/2	1 3/4	7 7/8	6 1/2	3 11/16	1 1/2	8 1/2	9 1/2	5 3/16	1	9 1/4	11	9 3/8	5 1/4
		2	1 1/4												5 3/4
		2	1 3/4												6

BALL & PLAIN BEARING DIE SETS

FLANGED TWO POST STYLES

BOLT CIRCLE DIAMETERS

DEMOUNTABLE BALL BEARING BUSHINGS	
NOMINAL BUSHING DIAMETER	BOLT CIRCLE DIAMETER
1	2.438
1 1/4	2.813
1 1/2	3.125
1 3/4	3.438
2	4.000
2 1/2	4.500
3	5.000

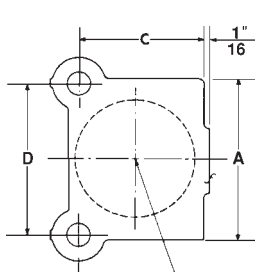

SEE DIAMETER IN TABLES

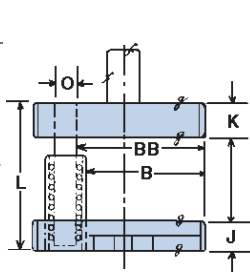
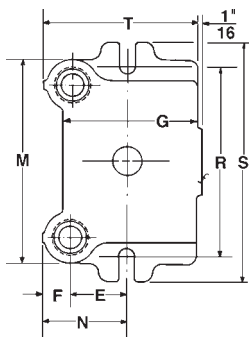

BALL BEARING

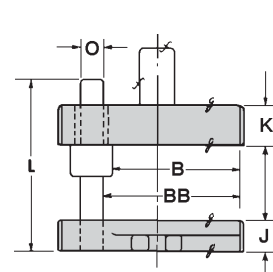

PLAIN BEARING

DEMOUNTABLE BALL BEARING PINS

NOMINAL BUSHING DIAMETER	BOLT CIRCLE DIAMETER
1	1.750
1 1/4	2.000
1 1/2	2.250
1 3/4	2.625
2	2.875
2 1/2	3.375
3	3.875

NOMINAL DIMENSIONS																
Left to Right	Front to Back	Die Holder	Punch Holder	C	D	E	F	G	M	N	O	R	S	T	Min. Shut Height	
A	B (BB)	J	K												L	
8 1/2 long	4 (4 3/8)	1 1/2	1 1/4	4 7/8	7 3/4	2 5/16	1 1/2	5 1/2	10 3/4	3 13/16	1	10 5/8	12 1/2	6 3/8	5 1/4	
		2	1 1/4												5 3/4	
8 1/2 reg.	8 (8 3/8)	1 1/2	1 1/4	8 7/8	7 3/4	4 3/16	1 1/2	9 1/2	10 3/4	5 11/16	1	10 5/8	12 1/2	10 3/8	5 1/4	
		1 1/2	1 3/4												5 3/4	
10 - reg.	10 (10 3/8)	1 5/8	1 3/8	11	10 1/4	5 1/4	1 13/16	11 3/4	13 7/8	7 1/16	1 1/4	12 1/4	13 7/8	12 13/16	6	
		2 1/4	1 3/4												7	
15 long	7 (7 3/8)	1 1/2	1 1/2	8 1/8	14	4 3/8	2 1/16	9	18 1/8	6 7/16	1 1/2	17 1/4	19 1/2	10 3/16	6 1/2	
		2	1 1/2												7	

WHEN ORDERING, SPECIFY:

- Select either Ball Bearing or Plain Bearing in the required size, grade, and thickness combination.
- Specify clamp arrangement (L-R feed or F-B feed) from drawing shown at right.
- Specify the quantity.
- Specify the type of bushing.
- Specify length "L". For Ball Bearing sets, this is the Minimum Shut Height dimension. For Plain Bearing sets, this is the dimension from the bottom of the die holder to the top of the guide post.
- Specify "no shank" or "Lempcoshank." If "Lempcoshank," give the catalog number of the kit desired. For 0604-GA-1 and GD-1 kick press sets, specify **one** of these:
 1" diameter x 2 1/8" long **OR** 1 9/16" x 2 1/8"
- Specify thickness combinations other than shown. Special or exact thicknesses are available at extra cost.
- All shipments are via our designated carrier unless otherwise specified.

NOTE: All LEMPCO Plain Bearing die sets will be assembled with Lamina Plain Bearing components.

DEMOUNTABLE SHOULDER BUSHING CLAMP ARRANGEMENT SELECTION DATA			
NOM. POST DIA.	A (L-R FEED)	B (F-B FEED) (CENTER POST SETS)	C (ROUND DIES)
1, 1 1/4 & 1 1/2			
1 3/4, 2, 2 1/2 & 3			
1 3/4, 2, 2 1/2 & 3			
1 3/4, 2, 2 1/2 & 3			

LEMPCO will honor all existing Ball Bearing and Plain Bearing catalog die set part numbers (BT, LT, BF, LF, BB, P).

SPECIALTY ITEMS

ACCU-BEND™ ROTARY BENDERS

SIMPLYIFYING YOUR BENDING PROCESS WITH ACCU-BEND™ ROTARY BENDERS!

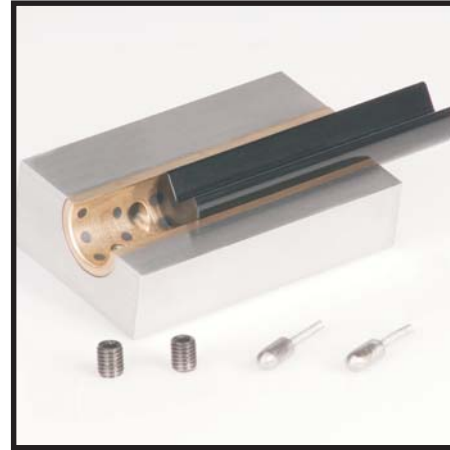

Accu-Bend™ units include a tool steel Rocker set into a steel Saddle with a graphite plugged Aluminum-Bronze liner. Available in standard inch and metric sizes with Rocker diameters of 20mm-80mm (0.75" - 3.0") and lengths of 50mm-900mm (2.0" - 35.0"), these units transfer the vertical motion of the press into a smooth one-motion rotation. The smooth rotation provides a rotary bend process which requires less tonnage and less strain on the material. The Accu-Bend™ Rotary Bender can also include optional pre-configured mounting hole patterns.

The saddle liner is a bronze alloy chosen for the ability to hold up to a bearing load with little to no wear while the graphite plugs are included in the bronze liner to provide lubrication. Both Rockers and Saddles are machined for precision and interchangeability. Compact benders fit in tight places and are ideal for bending small tabs within a larger part. Specials can be manufactured for your custom needs as well when an off-the-shelf product doesn't work for your application.

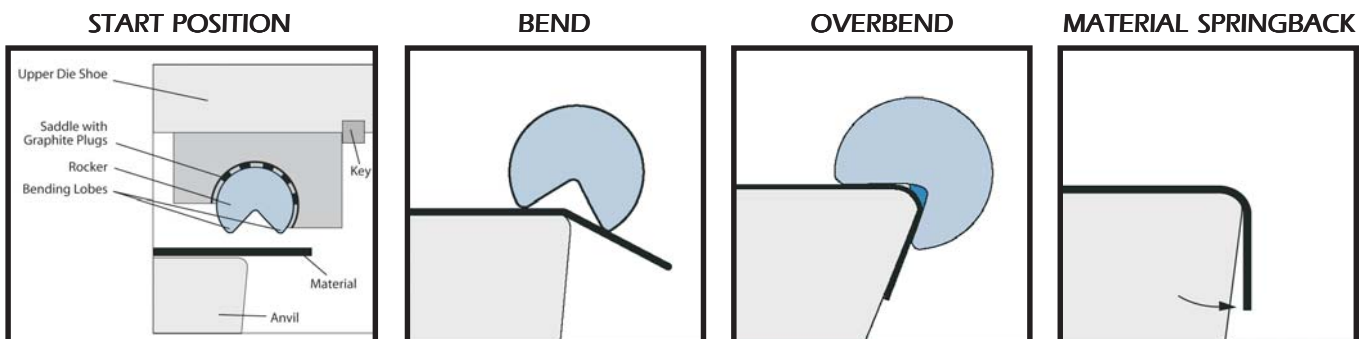

- ◆ Holds $\pm 1/2$ degree angle tolerance
- ◆ Overbends up to 120° for special part design and pre-hem applications
- ◆ Decreases forming tonnage by 40-80% over wipe tooling and "V" dies
- ◆ Forms channel bends in one hit by pairing two bends together

FORMATHANE® URETHANE

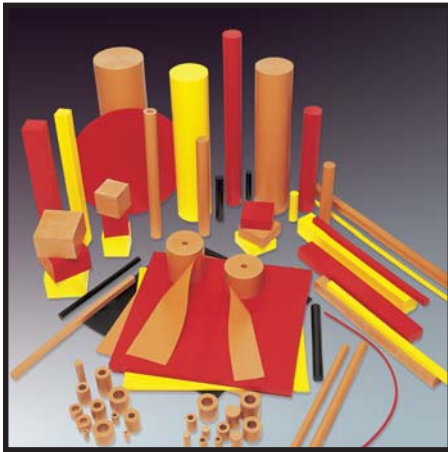

The Formathane® product line of urethane bars, rods, sheets, springs, film and strippers stands alone when compared to other urethane products offered in the market. Formathane® is formulated with the metalforming and fabricating user in mind to withstand the rigors of these difficult environments. Every day customers are putting it to the test and are finding double and triple life expectancies are more the norm than the exception with Formathane®. The higher than average performance is due to using premium grade urethane compounds, computer controlled production methods and stringent quality standards. Often used for springs, strippers, wear pads, vibration dampening, forming and part protection, Formathane® is offered in four durometers from 70 – 95A.

JIS SPRINGS



As a manufacturer of high quality springs in all standard ISO sizes, we also have available a line of true metric springs, in all the standard JIS (Japanese Industrial Standards) sizes and color load ratings. This extension of the spring line gives more options to customers with exacting requirements, making them available from the same reliable source as the inch springs. Manufactured in an optimal rectangular design and from a high strength chromium alloy material, these springs provide stability between load deflection and cycle life. The JIS product offering includes over a 1,000 part numbers divided into five duty groups (colors), with fourteen diameters available per diameter and free lengths from 20mm to 300mm.

PUNCHES



We offer a comprehensive range of standard punches and die buttons in the basic, ball lock and variable precision series. Each component is made of quality heat treated tool steel which meets or exceeds ANSI standards. They are available in A2 high performance tool steel for toughness and economy, and M2, high speed steel, triple-tempered for long runs where abrasion resistance is required. Also available as a special option is PM4 which offers improved wear and impact characteristics ideal for optimum performance at high operating speeds.

SPECIALTY ITEMS

MISCELLANEOUS

SURFACE MOUNT BALL BEARING ASSEMBLIES



LEMPCO now offers a new low cost ball bearing component assembly alternative added to our die components guiding system product line. These new additions, Surface Mount Ball Bearing Assemblies, are mounted directly to the die holder and punch holder rather than the conventional method. These assemblies are available in 32mm, 38mm, 50mm and 60mm diameters, while lengths range from 100mm to 350mm, depending on diameter. Complete assemblies will include the necessary mounting bolts and dowel pins required for installation as well as optional tapped mounting holes to secure Stroke End Blocks. Surface Mount Ball Bearing Assemblies are available as stand-alone assemblies or mounted to precision ground, machined to customer specifications, **LEMPCO** die sets.

DIE ACCESSORIES



A complete line of inch and metric pressroom accessories, including fasteners, hoist rings, stripper bolts, punch holder shanks, roller stock guides, stock pushers, pry bars, ball bearing and die lubrication and pad retainers are available. With parts manufactured from heat-treated, high strength alloy steel and machined to precise tolerances, you can be sure they are inspected to assure uniform hardness, quality and dimensions.

BOLSTERS AND STEEL PLATE

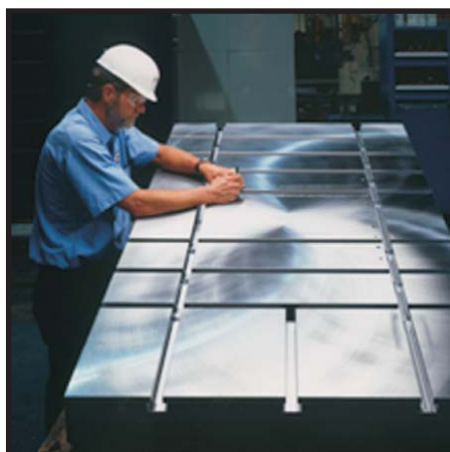

Bolster plates for Open Back Inclinable, Horning and Gap Frame and Large Press bolsters are manufactured to customer specifications. Bolsters for presses in these categories are built from steel. Steel plate has a combination of physical properties which make it suitable for a wide variety of industrial uses. Strong, hard and machinable, it is in stock and ready for immediate delivery. Furnish a drawing and we can cut, drill, grind, mill, bore, ream and tap. Stress relieving, heat treating and shot blasting services are also available.

SPECIALS TO MEET YOUR EXACT NEEDS

LEMPCO customization services will go to virtually any length to satisfy your needs. Now, the full range of answers to your requirements is at your command. It could be a simple modification or something quite exotic. Whatever your need, **LEMPCO** will work closely with you to select, design and manufacture products to meet your demands, while providing cost-effective solutions.

With our extensive machining capabilities, custom products can be manufactured outside the parameters normally found on our standard products and can include a variety of features.

COMPONENTS MANUFACTURING CAPABILITIES:

- ◆ Finished outside diameters from 5/8" x 20" length to 5" x 60" length
- ◆ Finished inside diameters
 - ▶ Hardened Steel – 1/2" x 4" length to 3 5/8" x 14" length
 - ▶ Bronze Plated Steel – 1/2" x 4" length to 4 1/2" x 9" length
 - ▶ Solid Bronze (w/wo graphite plugs) – 5/8" x 4" length to 6 1/8" x 7 7/8" length
- ◆ 3-Axis milling with part lengths up to 48"
- ◆ 5-Axis prismatic machining
- ◆ Surface grinding up to 96" length x 17" wide
- ◆ Hard turning
 - ▶ Maximum outside diameter: 3 3/4"
 - ▶ Minimum inside diameter: 1/2"
- ◆ Heat treating – alloy and low carbon steels up to 62HRC (size and carbon content dependent)
- ◆ Induction hardening
 - ▶ 1050 steel, up to 5 1/4" diameter and hardened to 58/62 HRC
 - ▶ 52100 steel, up to 3 3/4" diameter and hardened to 58/62 HRC

PLATING SERVICES AVAILABLE:

- ◆ Chrome Plating
- ◆ Copper Bronze Plating

SPRINGS MANUFACTURING CAPABILITIES:

- ◆ Outside diameters from 5/16" to 3" (7.9mm to 76mm)
- ◆ Free lengths from 1/2" to 36" (12.7mm to 914mm)
- ◆ Round spring wire from 0.040" to 1/2" (1.01mm to 12.7mm)
- ◆ Standard rectangular wire up to 0.375" x 0.469" (9.5mm x 11.9mm)

COATINGS AVAILABLE:

- ◆ Plain, no paint
- ◆ Oiled
- ◆ Electroless Nickel
- ◆ Chrome
- ◆ Zinc
- ◆ Powder or E-coat paint
- ◆ Mil-spec coatings
- ◆ Cadmium
- ◆ Dacromet®
- ◆ Others on request

High quality products, service and innovative development are key elements in our continued dedication to serving the needs of our customers.

LEMPCO®

VISIT OUR WEBSITE AT: www.lempco.com

CONTACT US AT:

Components

Email: lempco@lempco.com

Call: 800-652-6462

Fax: 800-406-4410

Die Sets

Email: quotes@lempco.com

Call: 800-321-8632

Fax: 800-221-6310



OUTSIDE THE USA & CANADA

CALL: 001-248-489-7816

FAX: 001-248-553-6842

